



3-in-1 EZ Fold Wagon

model/modèle/modelo #3955

For ages over 1 1/2 years.
 Pur les enfants âgés de plus d'un et demie.
 Para niños de más de 18 meses.



Register this product at www.radioflyer.com/register
 for a chance to win a Free Radio Flyer product!
 (One winner selected every month!)

Thank you for your purchase. If you have any questions or comments, please visit the customer service section of our website:

Merci d'avoir acheté notre produit. Si vous avez des questions ou commentaires, veuillez référer notre site web dans la section de service à la clientèle:

Gracias por su compra. Si tiene preguntas o comentarios por favor visite la sección, servicio al cliente de nuestro website:

www.radioflyer.com

Or phone / ou composez le / o llame al 1-800-621-7613
 Available weekdays 8:00 a.m. to 5:00 p.m. CST.
 Please keep this sheet for future reference.
 Disponible sur semaine de 8:00 heures 17:00 heures.
 Veuillez garder cette feuille comme référence.
 De lunes a viernes de 8:00 a.m. a 5:00 p.m. CST.
 Por favor retenga esta copia para futura referencia.

Radio Flyer Inc. / 6515 West Grand Ave. / Chicago, IL 60707
 phone: 1-800-621-7613

The Original Little Red Wagon™ - Since 1917

1 Required:
 Nécessaire:
 Requeridas:

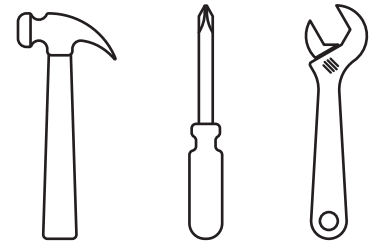

2

302872 (x1)

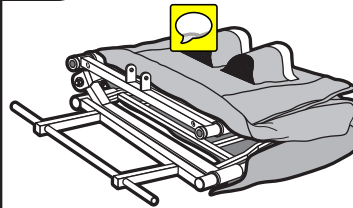

301787 (x2)



301782 (x1)

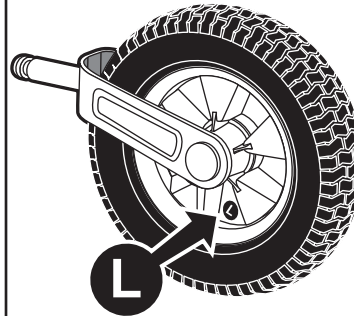

301783 (x1)

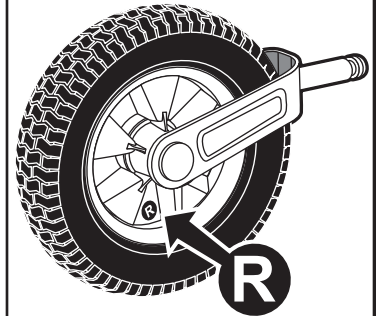

3

103192 (x2)

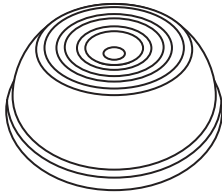

- ! If you find extra hardware items, please dispose of them and keep them away from small children.
- ! Si vous avez de éléments en surplus, rangez-les dans un endroit sûr, à l'abri des bambins.
- ! Deshacerse de la ferreteria que le sobre, manteniéndolo fuera del alcance de los niños.

302270 (x1)

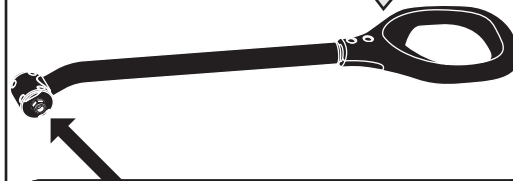

302277 (x1)

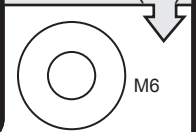

302278 (x1)

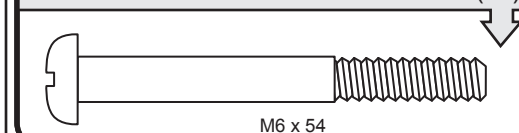

302271 (x1)

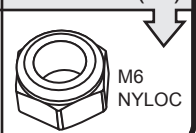

4 **! WARNING:**

ADULT ASSEMBLY REQUIRED.
 Choking hazard to children under the age of 3 years – contains small parts prior to assembly. All fasteners should be fully tightened.

Please keep instructions for future reference.

! AVERTISSEMENT:

ASSEMBLAGE REQUIS PAR ADULTE.
 Risque d'étouffement pour le enfants de moins de trois ans – Contient des pièces de petite taille avant assemblage. Toutes les attaches devraient être bien serrées.

Veuillez garder les instructions comme référence aux besoins.

! ADVERTENCIA:

MONTAJE REQUERIDO POR ADULTOS.
 Peligro de asfixia an niños menores de 3 años - contiene piezas pequeñas antes del montaje. Todos los seguros deben ser apretados completamente.

Mantenga por favor las instrucciones para la referencia futura.

5

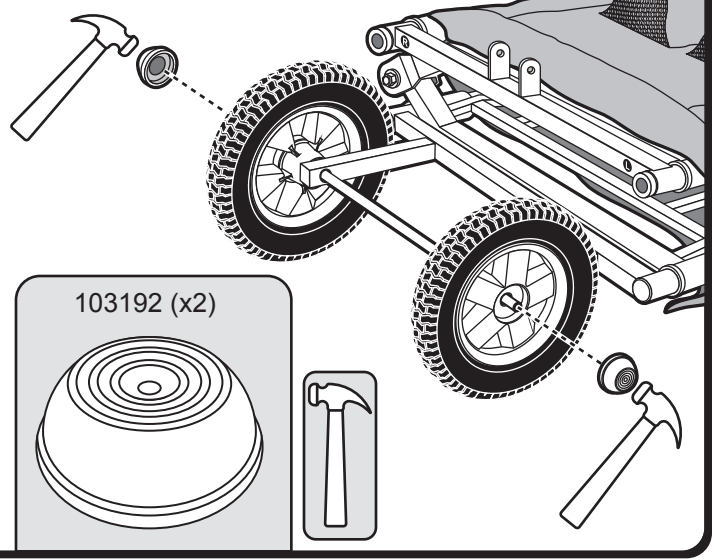
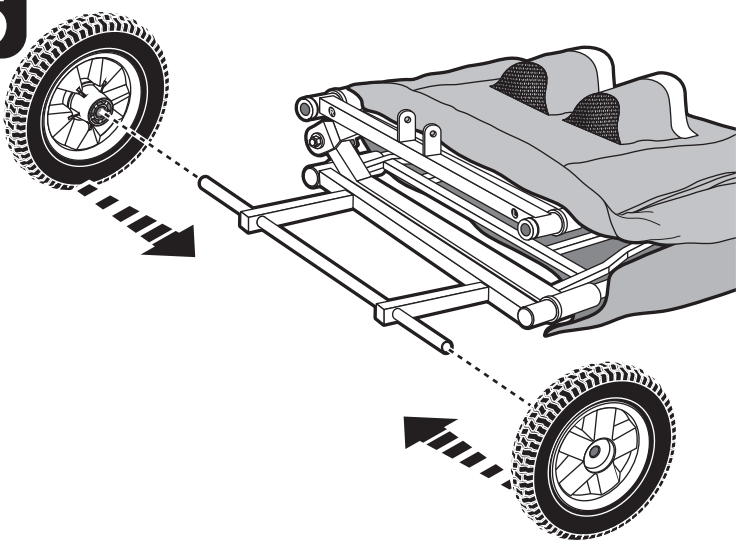

6

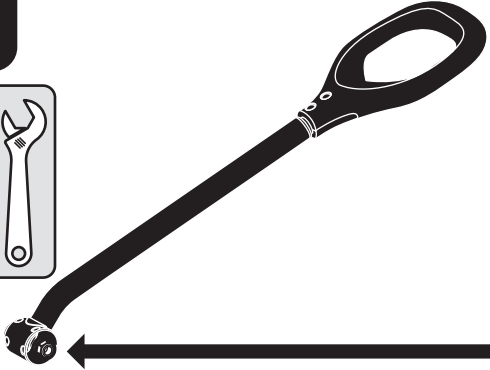

- Unscrew
- Dévisser
- Destornille

- Needed in step 7.
- Nécessaire dans l'étape 7.
- Se necesita en el paso 7.

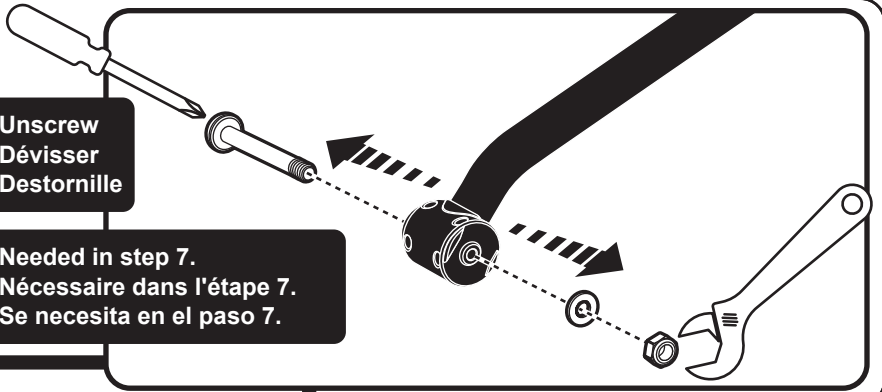

7

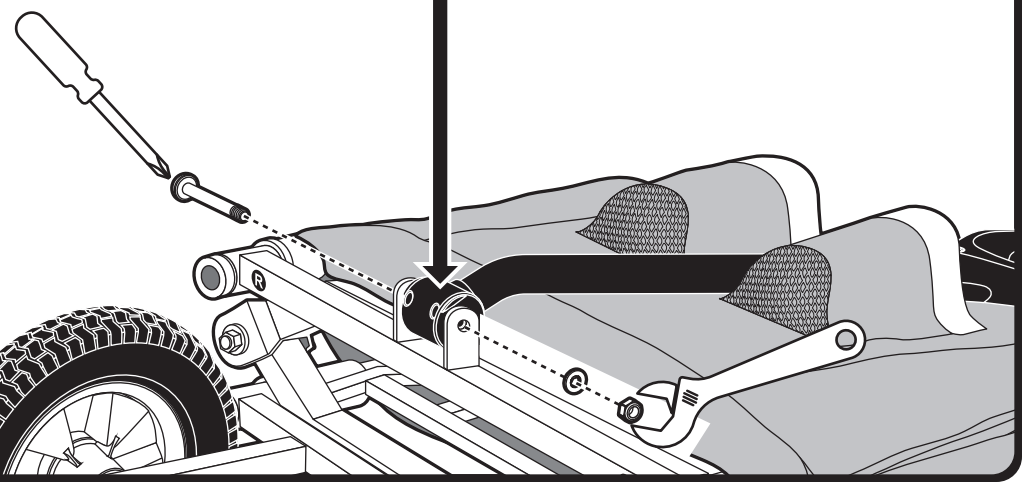
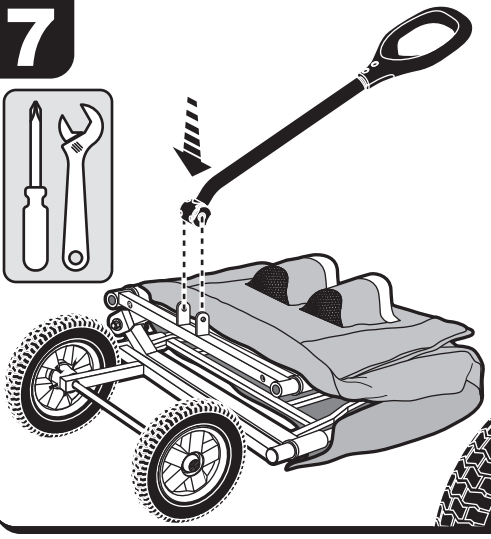

8 x2

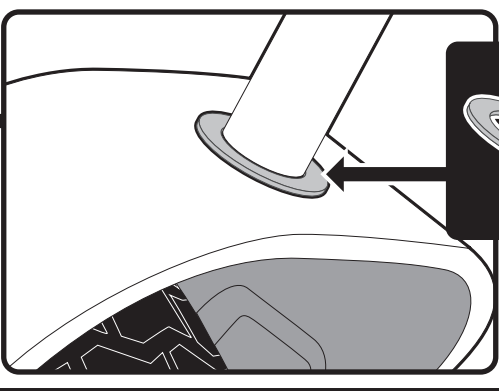
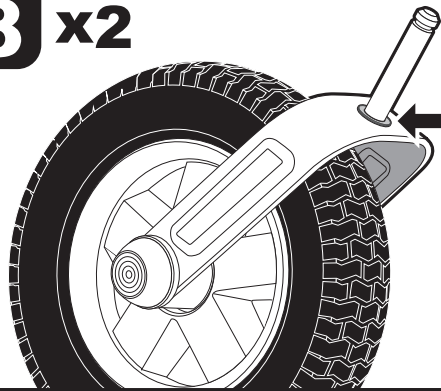

- Do not remove. Needed in steps 9 & 10.
- Ne pas enlever. Nécessaire dans les étapes 9 & 10.
- No quitar. Se necesita en los pasos 9 & 10.

9

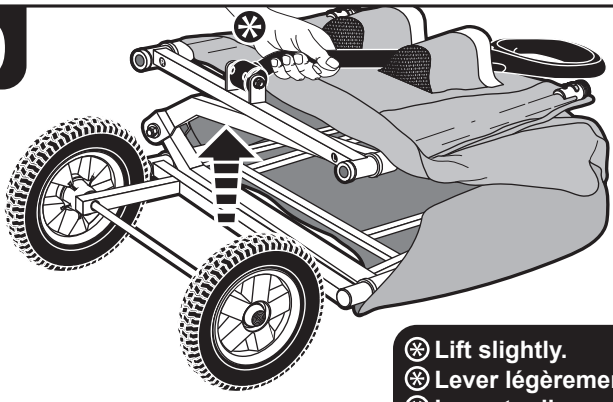

- ⊗ Lift slightly.
- ⊗ Lever légèrement.
- ⊗ Levantar ligeramente.

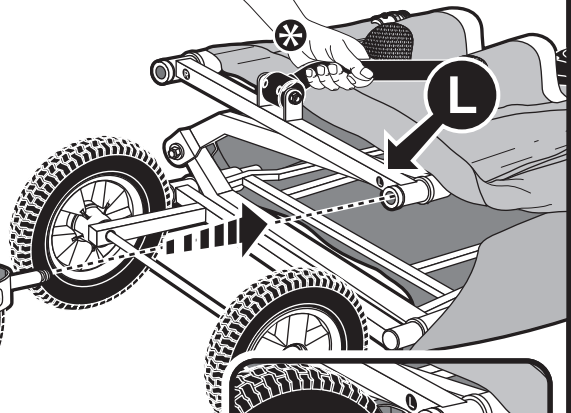

301782 (x1)

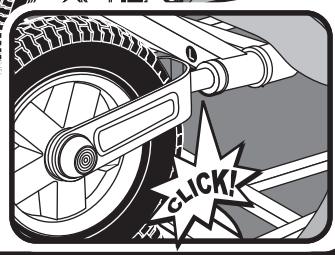

10

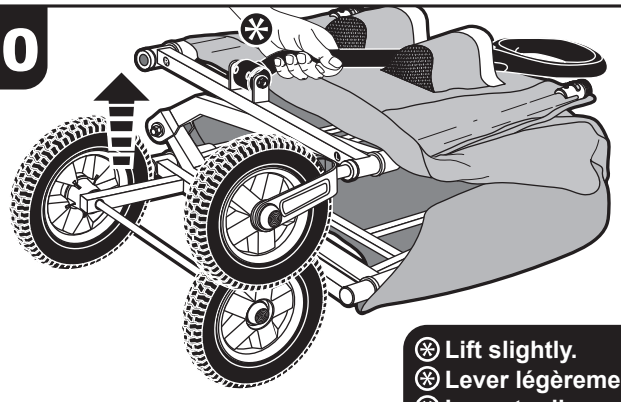

- ⊗ Lift slightly.
- ⊗ Lever légèrement.
- ⊗ Levantar ligeramente.

301783 (x1)

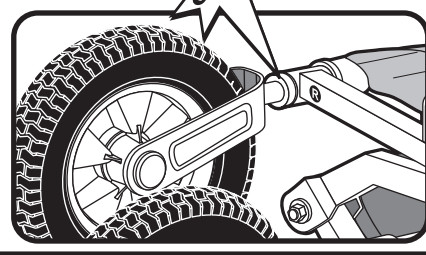
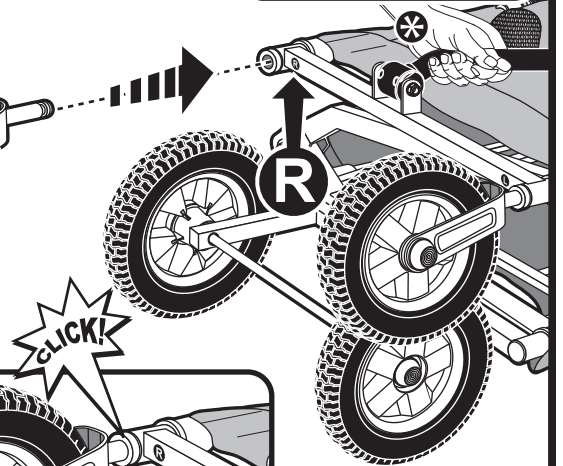

11

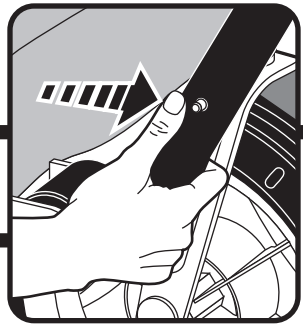
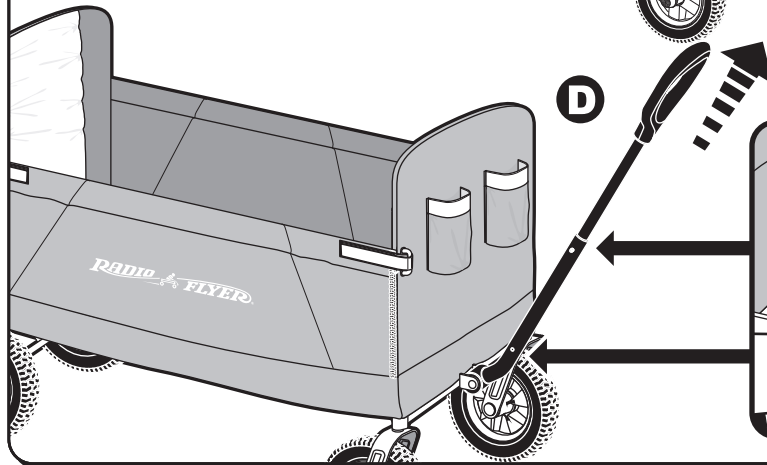
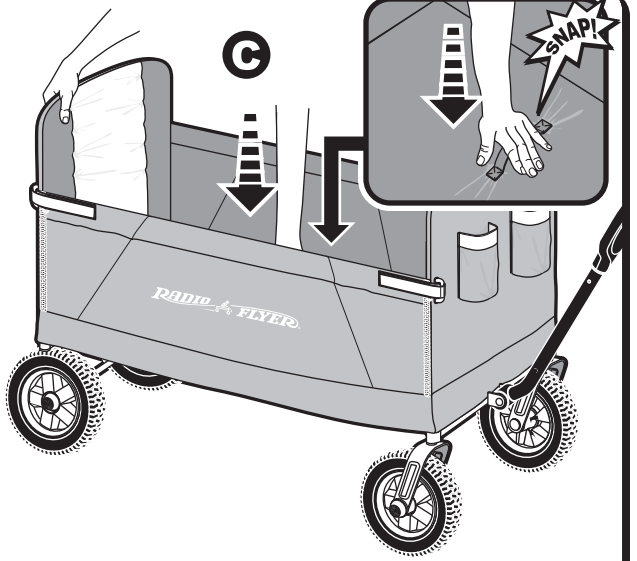
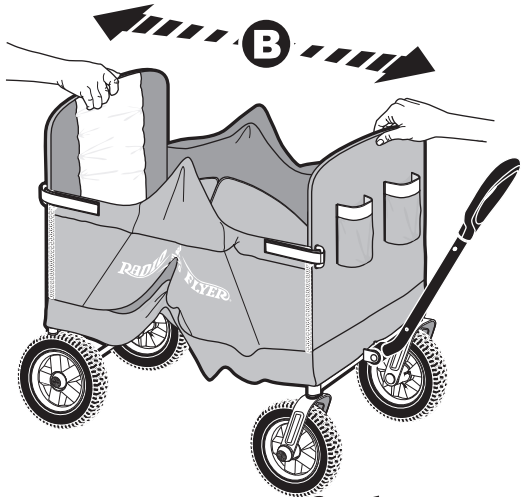
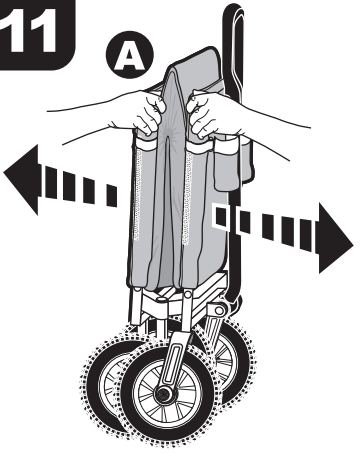

12

- Convert to bench.
- Convertir en banc.
- Convertir a la banca.

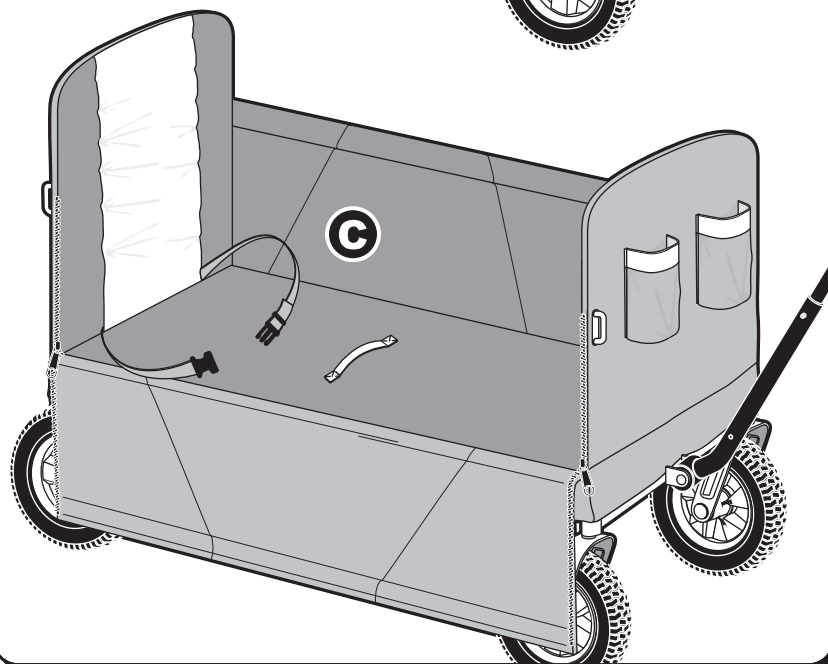
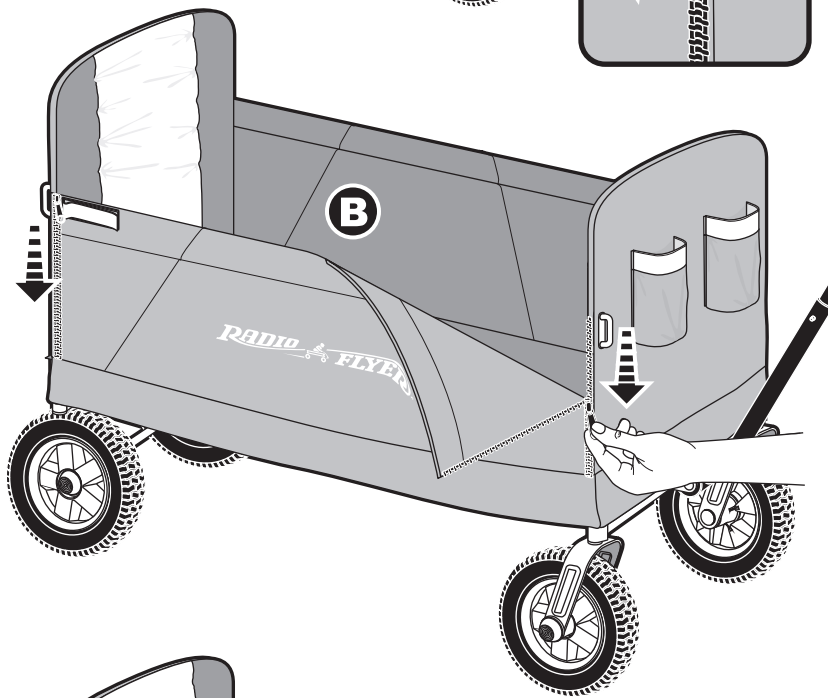
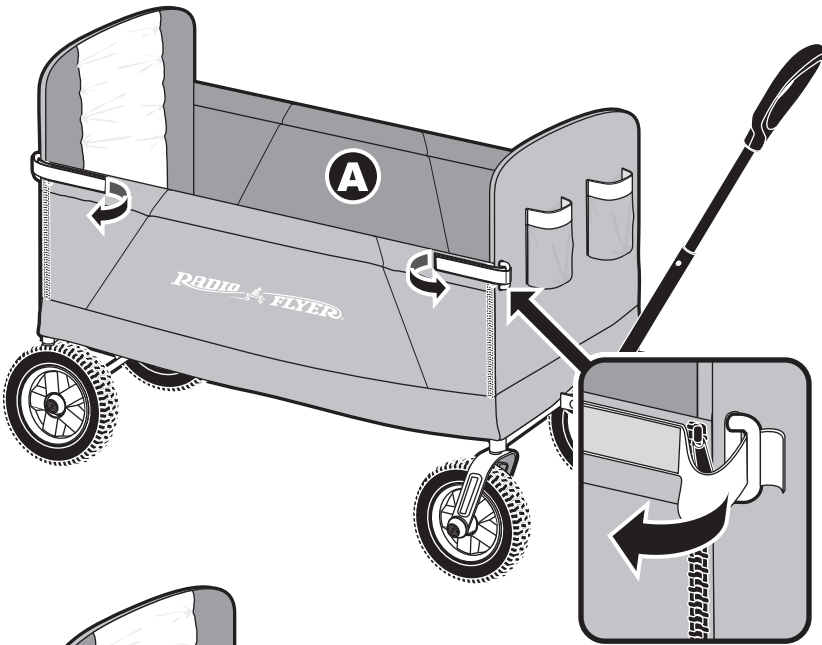

13

- Convert to wagon.
- Convertir en wagon.
- Convertir al vagón.

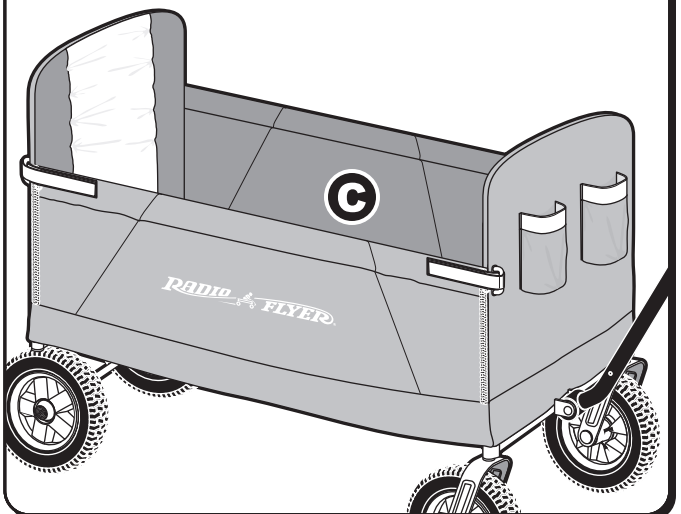
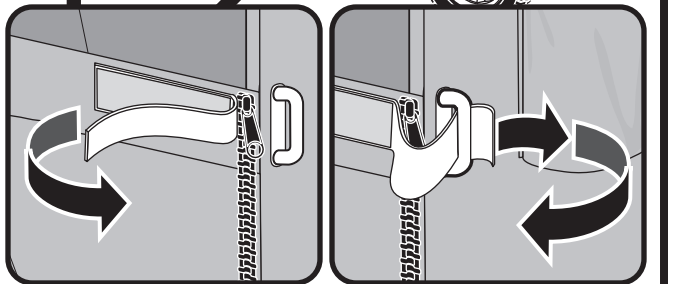
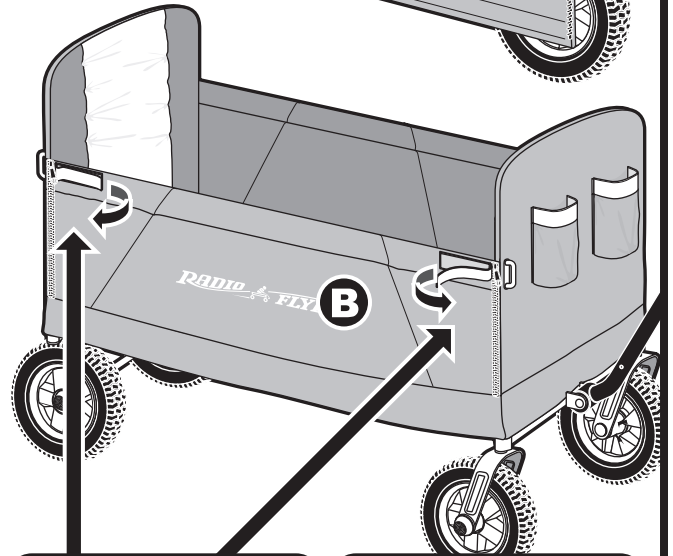
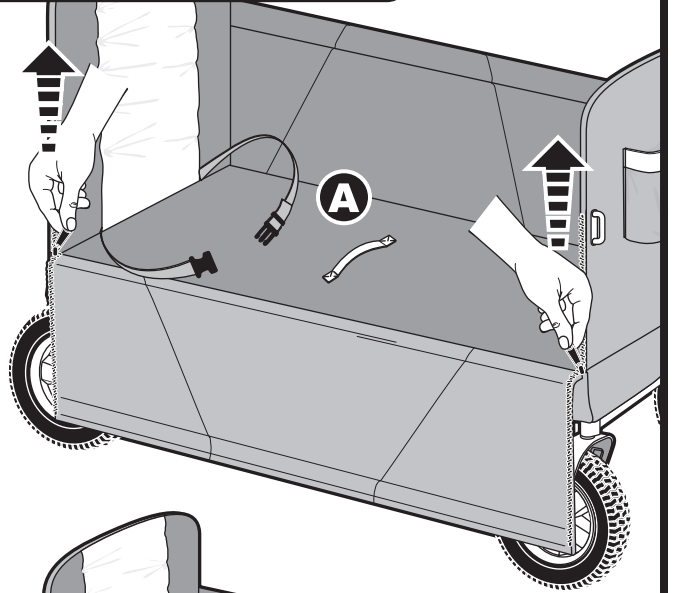

14 • For compact storage: • Pour un rangement compact: • Para un almacenamiento compacto:

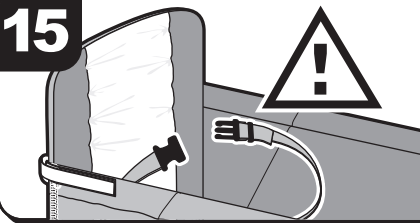
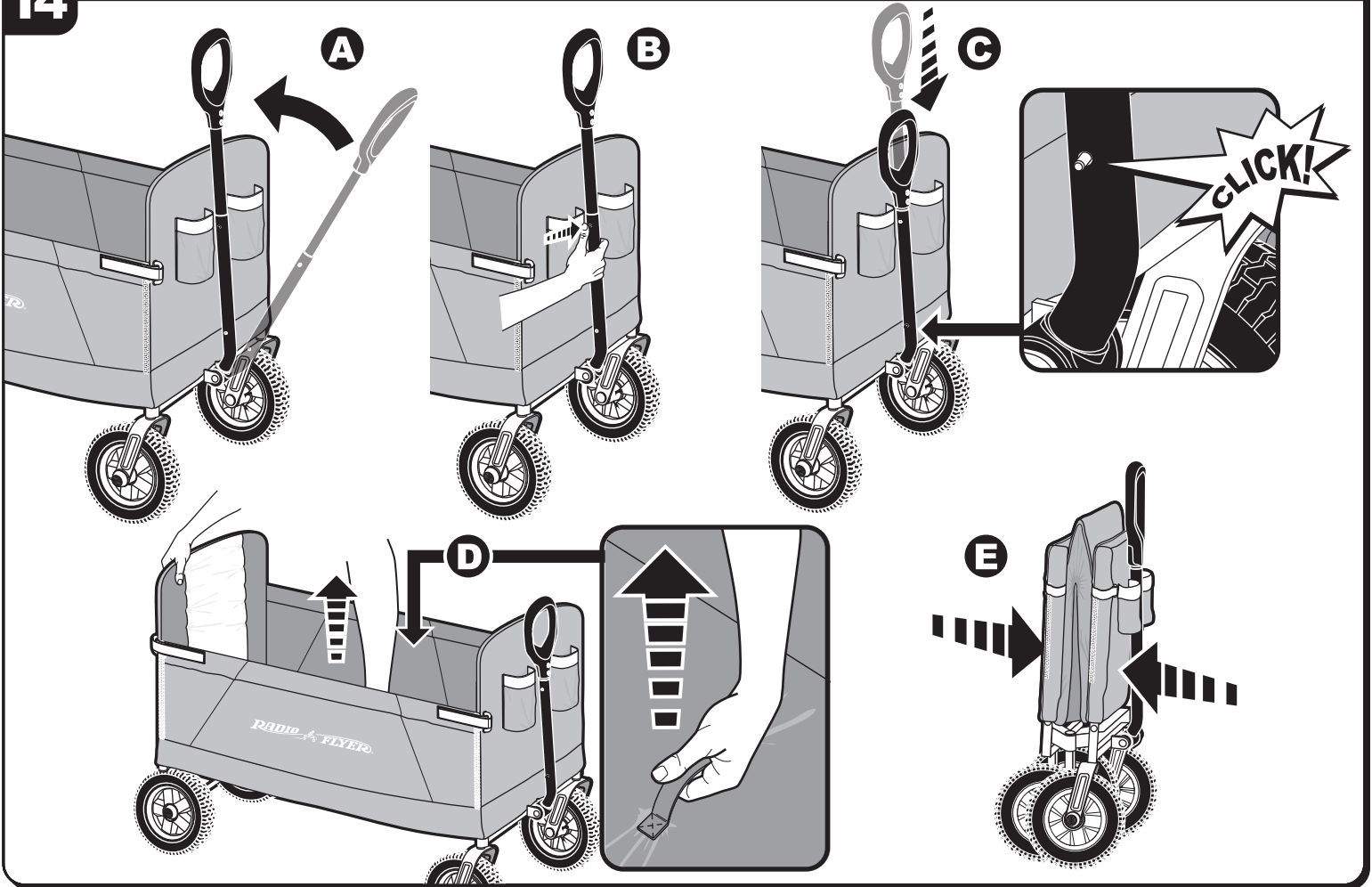

- 15** **CAUTION: Use harness to secure child to wagon seat.**
- ATTENTION: Utiliser harnais pur obteri l'enfant au siege de chariot.**
- PRECAUCIÓN: Use arcos para asegurar a niño asiento del carro.**

! WARNING:
TO AVOID SERIOUS INJURY:

- Continuous adult supervision is required.
- Never use near motor vehicles, streets, roadways, alleys, swimming pool areas, hills, steps, sloped driveways, inclines and public highways.
- No more than 2 riders at a time.
- Passengers should remain seated while riding the wagon.
- To prevent falls or injuries, children must remain seated with their arms and legs inside the wagon while riding.
- Never ride the wagon outside at night.
- Never use in wet weather.
- Maximum weight this wagon is designed to carry is 150.0 lbs (68.0 kg).
- Periodically check hardware and tighten if necessary. Replace worn or broken parts immediately.
- Unfold and lock wagon in riding position before use.
- Only adults should fold and unfold the wagon

! AVERTISSEMENT:
POUR ÉVITER TOUTE BLESSURE GRAVE:

- Ne jamais utilisez près des véhicules à moteur, des rues, des chaussées, des allées, au environs des piscine, des collines, des marches, est des descente en pente des allées, des pentes et des autoroutes publiques.
- Pas plus de 2 passagers en même temps.
- Les passagers doivent restés assis quand ils conduisent le chariot.
- Pour éviter toute chute ou blessure, les enfants ne doivent pas laisser dépasser leurs bras ou leurs jambes et rester assis dans le chariot lorsqu'il est en mouvement.
- Le chariot ne doit jamais être utilisé de nuit.
- Ne joue jamais avec ton chariot par temps de pluie.
- Le poids maximum que peut supporter le chariot est de 68.0 kg (150.0 livres).
- Vérifiez souvent les boulons et écrous et resserrez les si nécessaire. Remplacez les pièces usées out endommagées immédiatement.
- Déplier et verrouiller wagon en position de conduite avant de l'utiliser.
- Seuls les adultes devraient plier et déplier le wagon.

! ADVERTENCIA:
PARA EVITAR LESIONES GRAVES:

- La supervisión adulta continua requerida.
- Nunca uso cerca de automóviles, calles, carreteras, callejones, áreas de piscinas, colinas, pasos, calzadas inclinadas, inclinaciones y carreteras públicas.
- No se deben montar más de dos personas a la vez.
- Los pasajeros deben mantenerse sentados en todo momento mientras se está en el carrito.
- Para evitar caídas o lesiones, cuando los niños utilicen el carro deben permanecer sentados, sin sacar los brazos ni las piernas.
- Nunca use el carrito en exteriores durante la noche.
- Nunca usar el carrito si está lloviendo.
- El peso máximo que puede soportar es de 68.0 kg (150.0 libras).
- Compruebe el hardware y apriete periódicamente en caso de necesidad. Reemplace inmediatamente las piezas dañadas o gastadas.
- Despliegue y bloquee vagón en posición de conducción antes de su uso.
- Sólo los adultos deben plegar y desplegar lacarreta.