

RADIO FLYER Convertible Stroller Wagon

model/modèle/modelo #3970

For ages over 1 year.
Pur les enfants âgés de plus de 1 an.
Para niños de más de 1 año.



Register this product at www.radioflyer.com/register
for a chance to win a **Free Radio Flyer product!**
(One winner selected every month!)

Thank you for your purchase. If you have any questions or comments, please visit the customer service section of our website:

Merci d'avoir acheté notre produit. Si vous avez des questions ou commentaires, veuillez référer notre site web dans la section de service à la clientèle:

Gracias por su compra. Si tiene preguntas o comentarios por favor visite la sección, servicio al cliente de nuestro website:

www.radioflyer.com

Or phone / ou composez le / o llame al 1-800-621-7613

Available weekdays 8:00 a.m. to 5:00 p.m. CST.

Please keep this sheet for future reference.

Disponible sur semaine d e 8:00 heures 17:00 heures.

Veillez garder cette feuille comme référence.

De lunes a viernes de 8:00 a.m. a 5:00 p.m. CST.

Por favor retenga esta copia para futura referencia.

Radio Flyer Inc. / 6515 West Grand Ave. / Chicago, IL 60707

phone: 1-800-621-7613

The Original Little Red Wagon™ - Since 1917

1 Required:
Nécessaire:
Requeridas:

2

305794 (x1)	305795 (x2)
305796 (x1)	305797 (x1)
	 • Do not remove. • Ne pas enlever. • No quitar.
305799 (x1)	
306540 (x1)	305798 (x1)
	 • Do not remove. • Ne pas enlever. • No quitar.
305801 (x1)	

3 Hardware Bag 305811 (x1):
Sac matériel 305811 (x1):
Bolsa de tornillos 305811 (x1):

305802 (x2)	103192 (x2)	305803 (x2)	305805 (x2)	305806 (x2)
M6 x 40			306238 (x2)	305804 (x2)
306155 (x2)	305807 (x2)			
M6 x 36				

! If you find extra hardware items, please dispose of them and keep them away from small children.
Si vous avez de éléments an surplus, rangez-les dans un endroit sur, a l'abri des bambins.
■ Deshacerse de la ferreteria que le sobre, manteniéndolo fuera del alcance de los niños.

4 ⚠ WARNING:	⚠ AVERTISSEMENT:	⚠ ADVERTENCIA:
ADULT ASSEMBLY REQUIRED. Choking hazard to children under the age of 3 years – contains small parts prior to assembly. All fasteners should be fully tightened.	ASSEMBLAGE REQUIS PAR ADULTE. Risque d'étouffement pour les enfants de moins de trois ans – Contient des pièces de petite taille avant assemblage. Toutes les attaches devraient être bien serrées.	MONTAJE REQUERIDO POR ADULTOS. Peligro de asfixia an niños menores de 3 años - contiene piezas pequeñas antes del montaje. Todos los seguros deben ser apretado s completamente.
Please keep instructions for future reference.	Veillez garder les instructions comme référence aux besoins.	Mantenga por favor las instrucciones para la referencia futura.

5

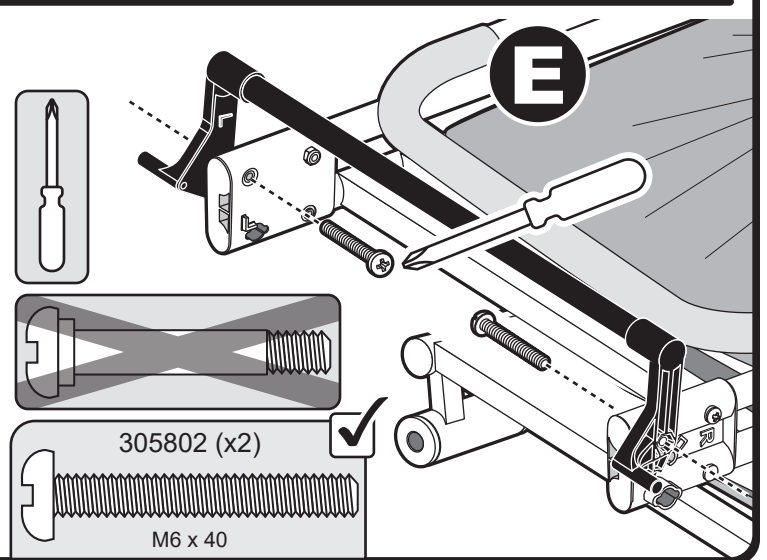
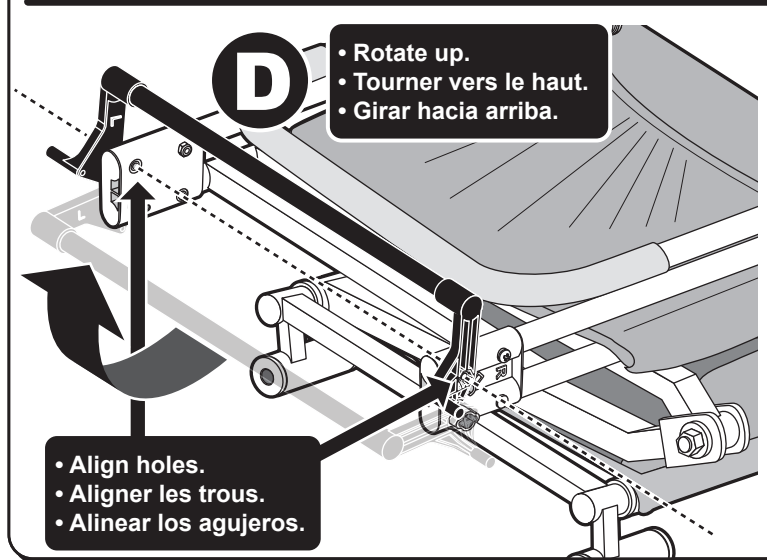
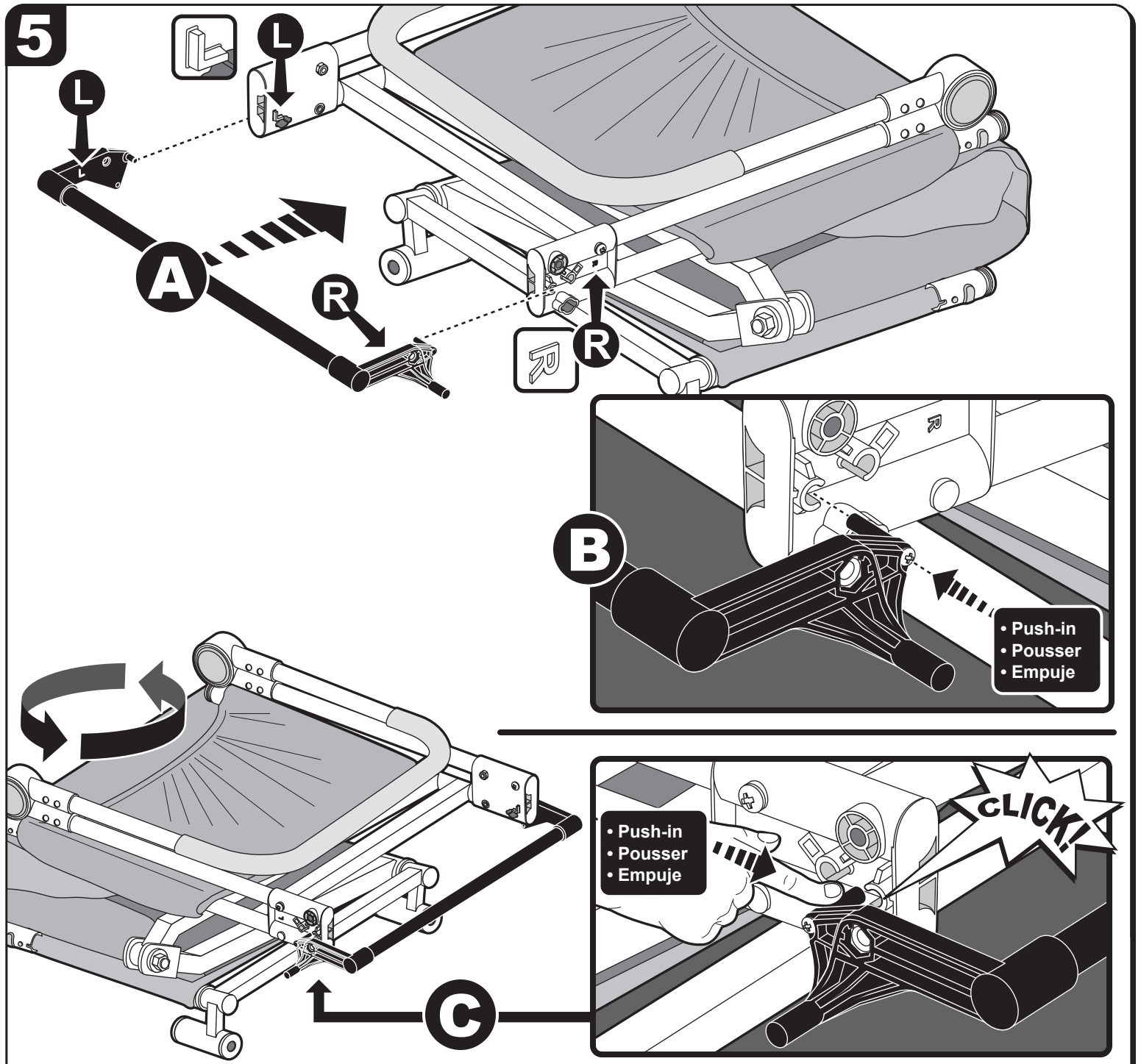

6 x1

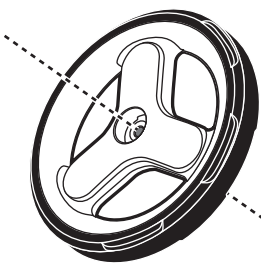

- Secure only 1 wheel.
- Seulement une roue.
- Solo una rueda

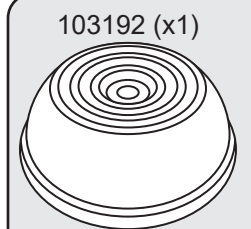
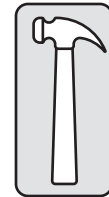
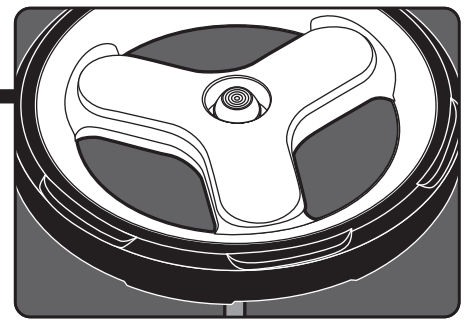
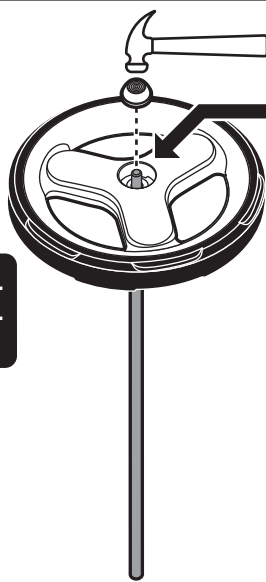

7

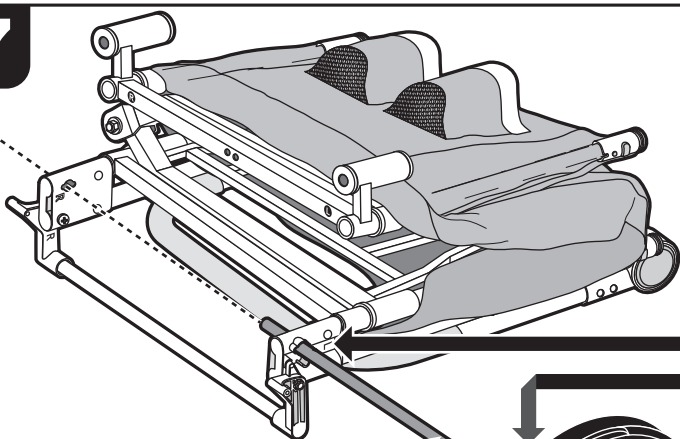

- Align
- Aligner
- Alinear

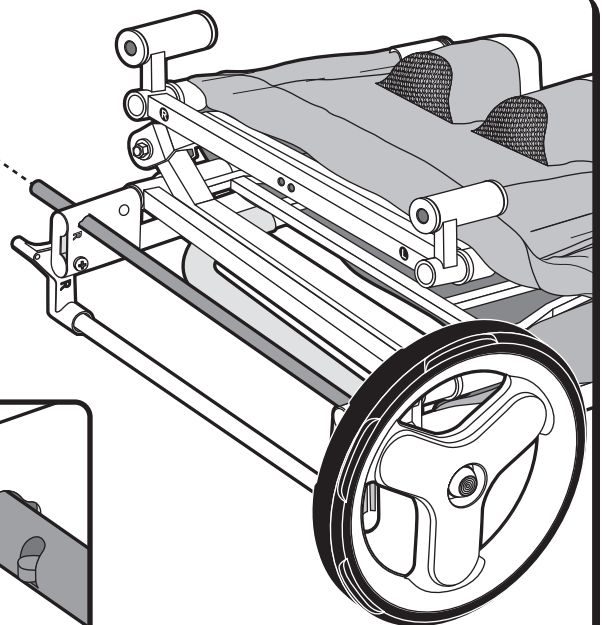
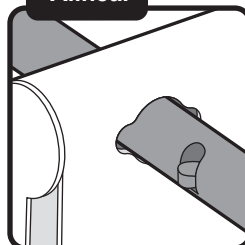
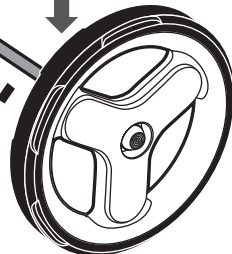

8

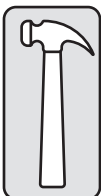

103192 (x1)

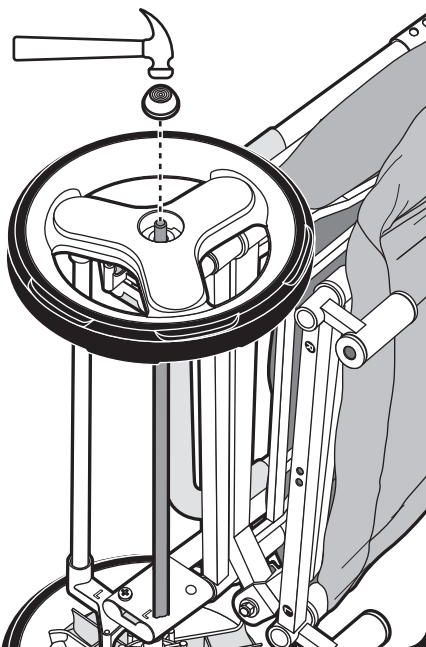
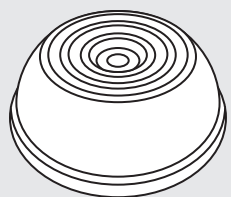

9 x2

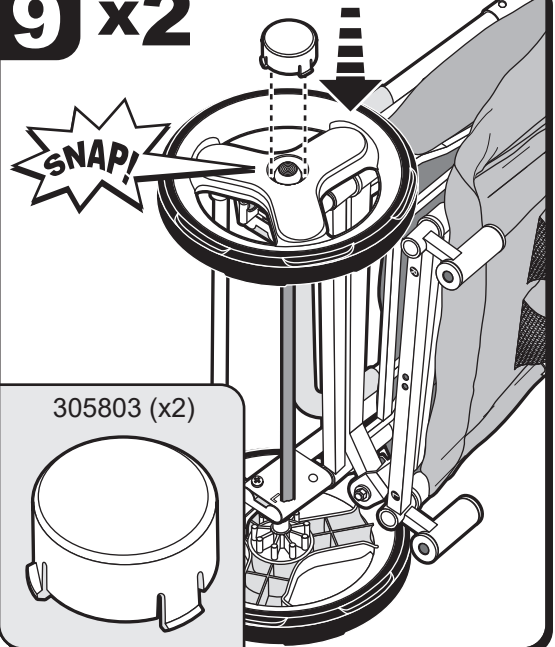

305803 (x2)

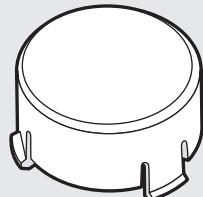

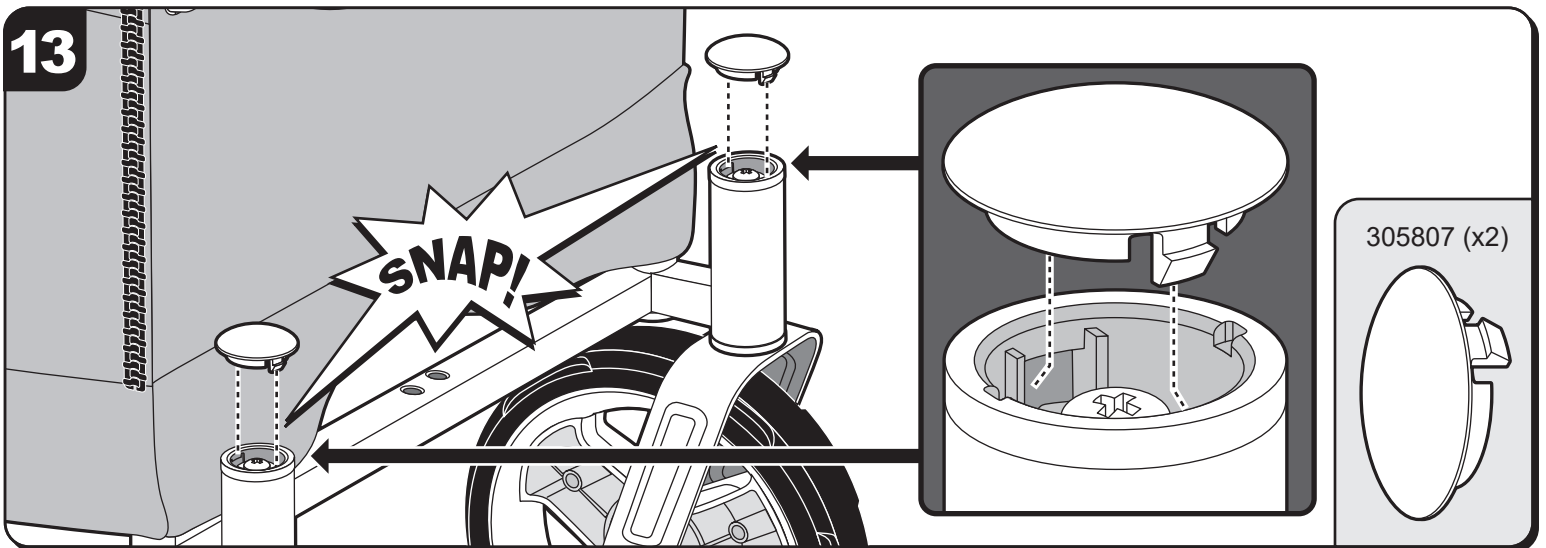
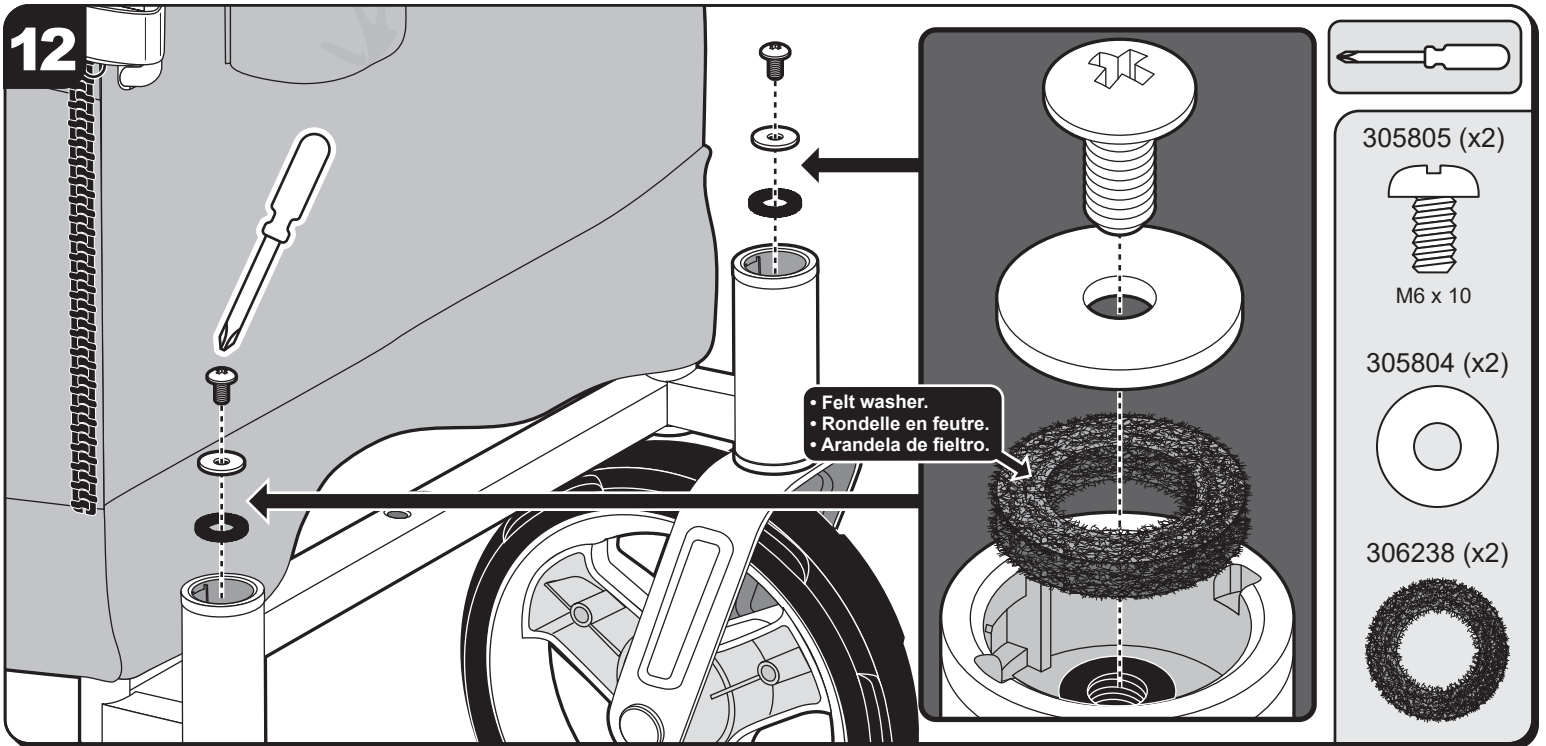
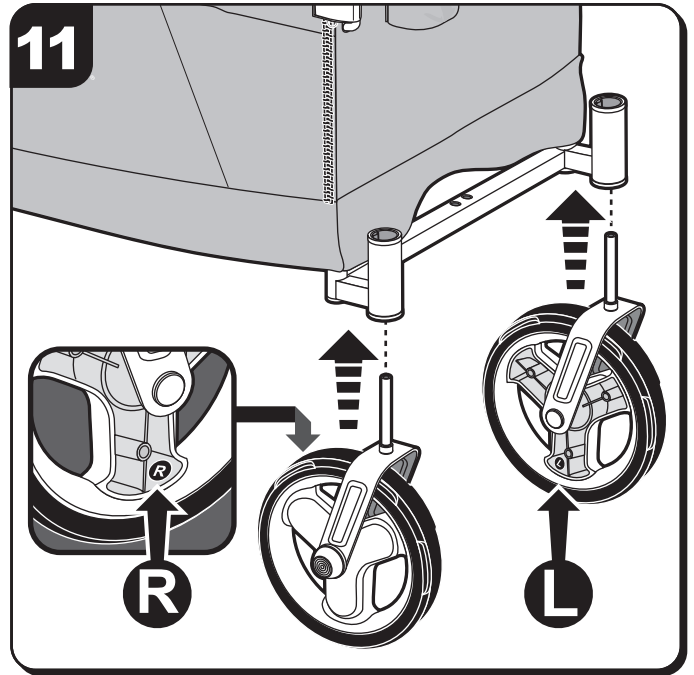
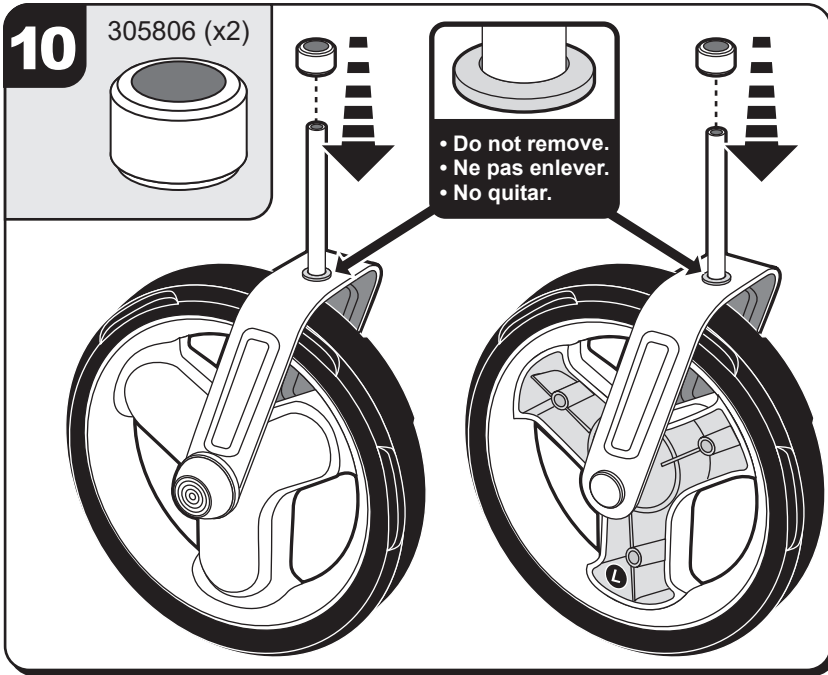

14

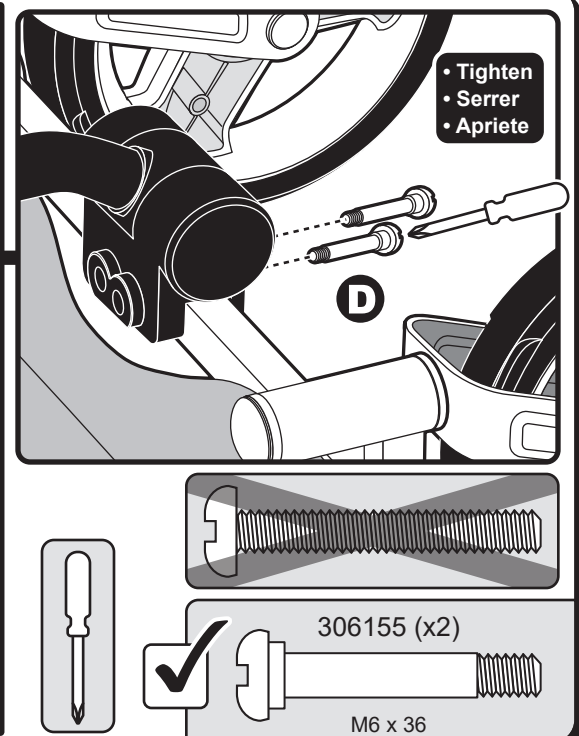
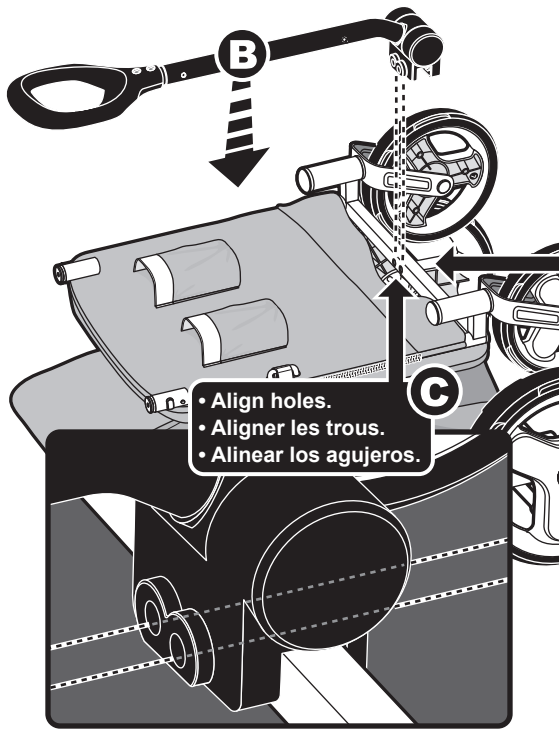
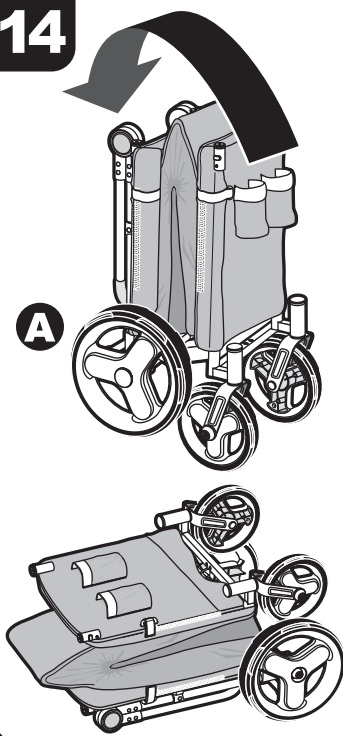

15

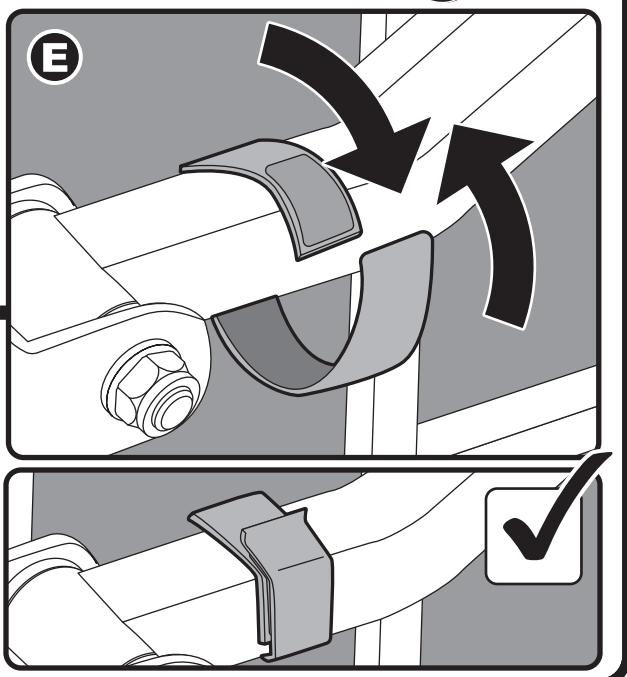
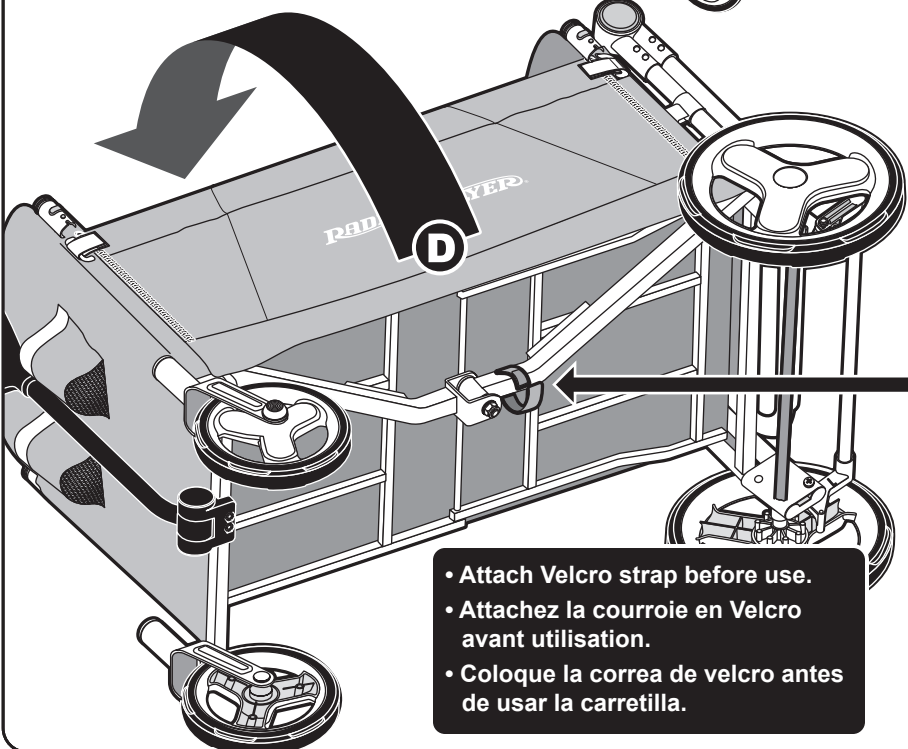
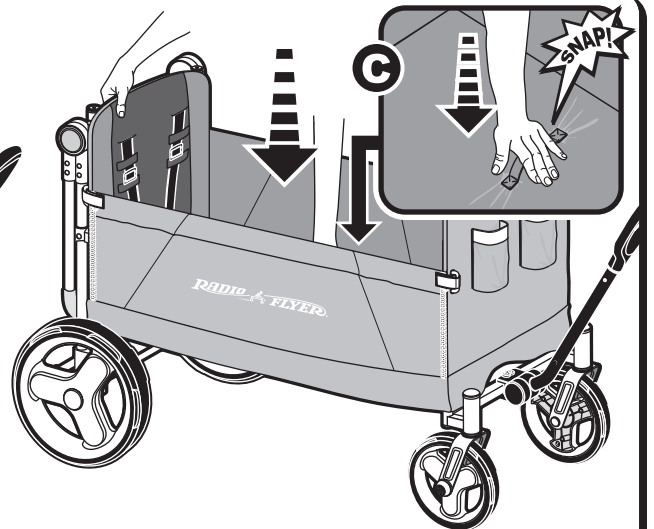
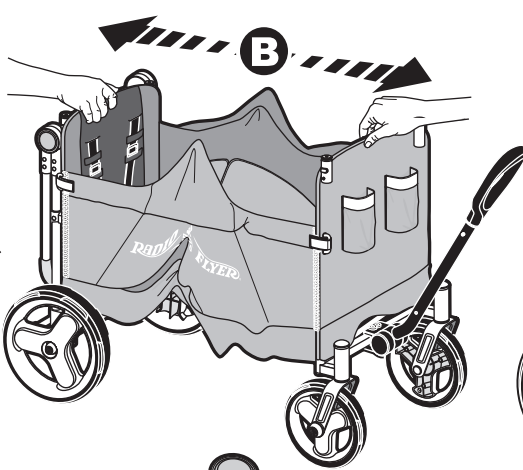
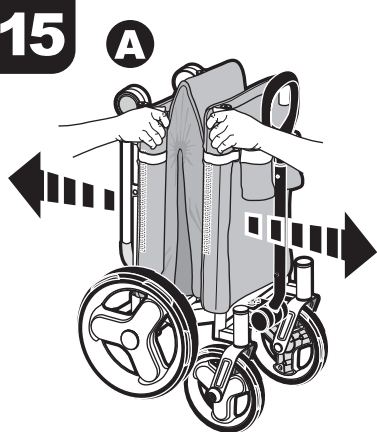

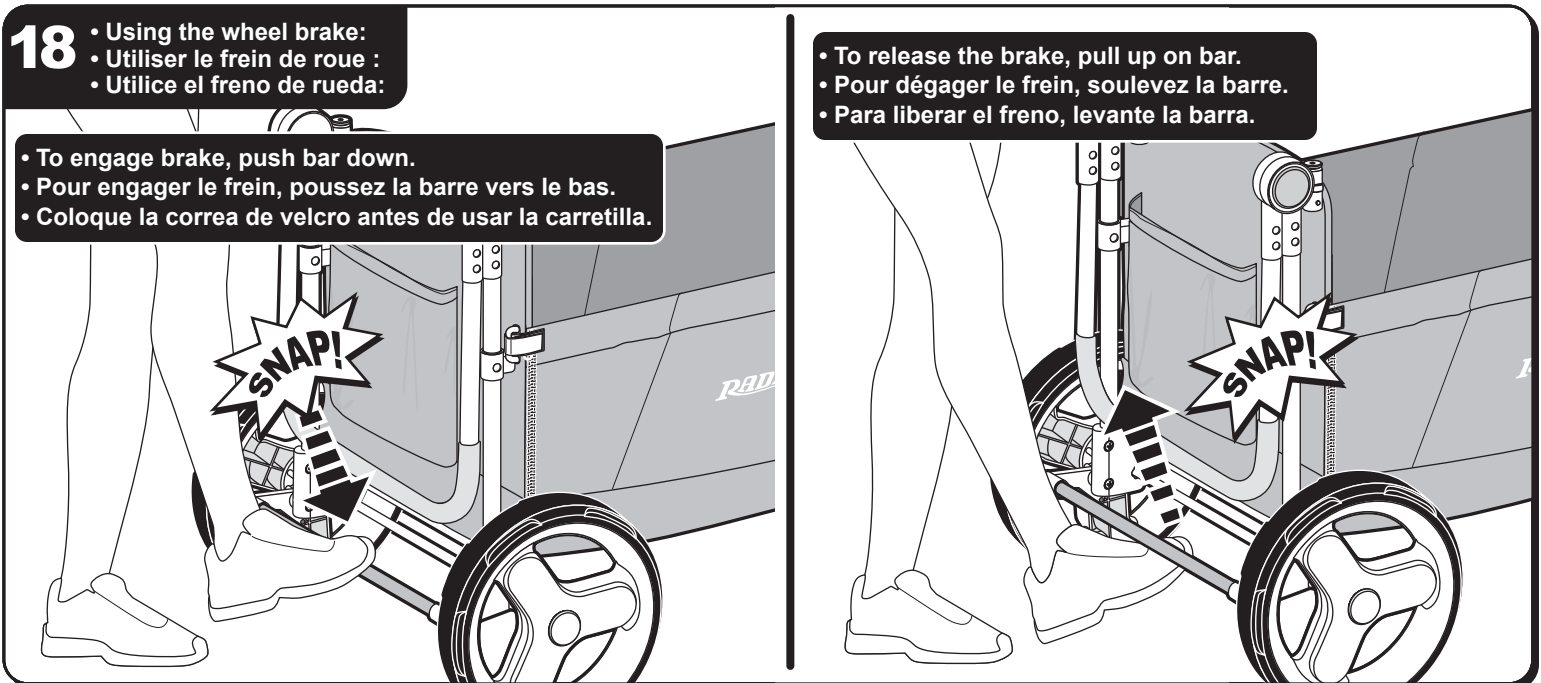
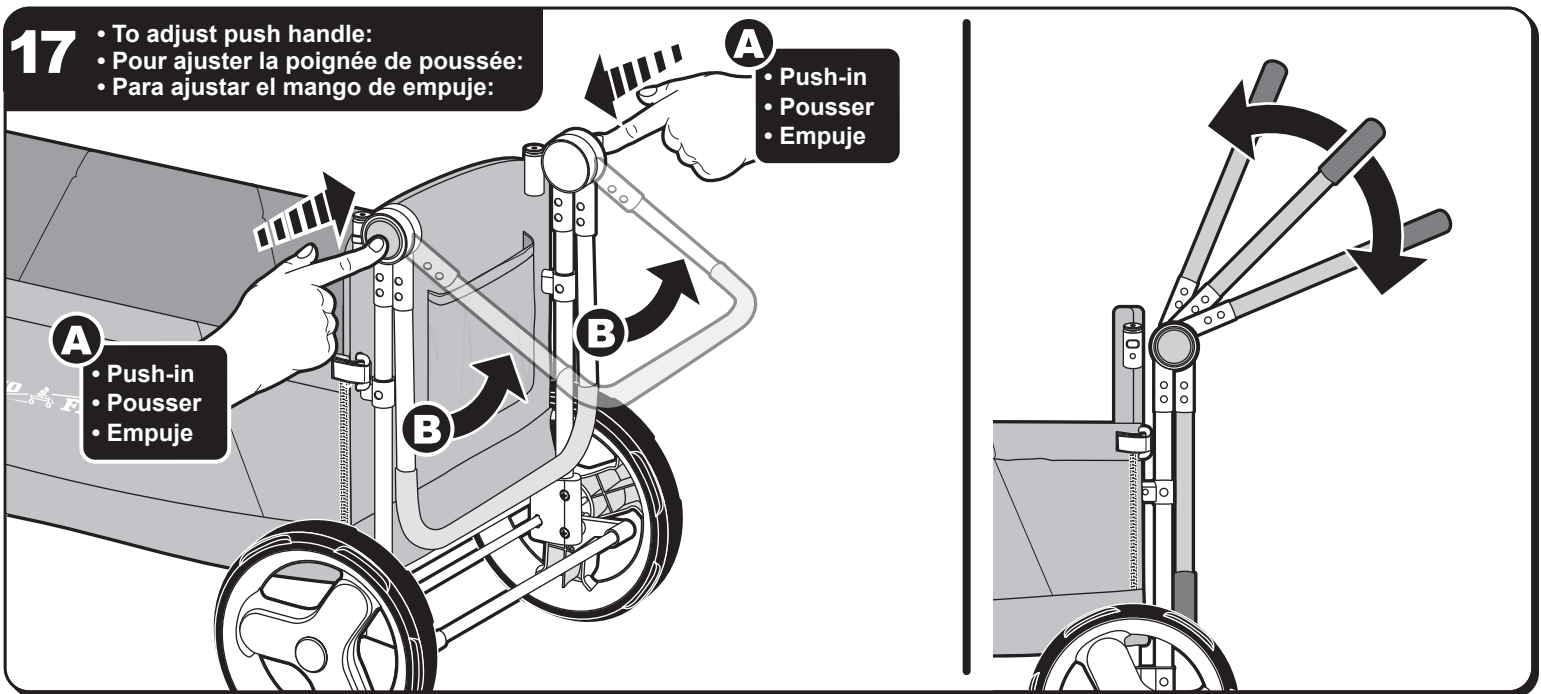
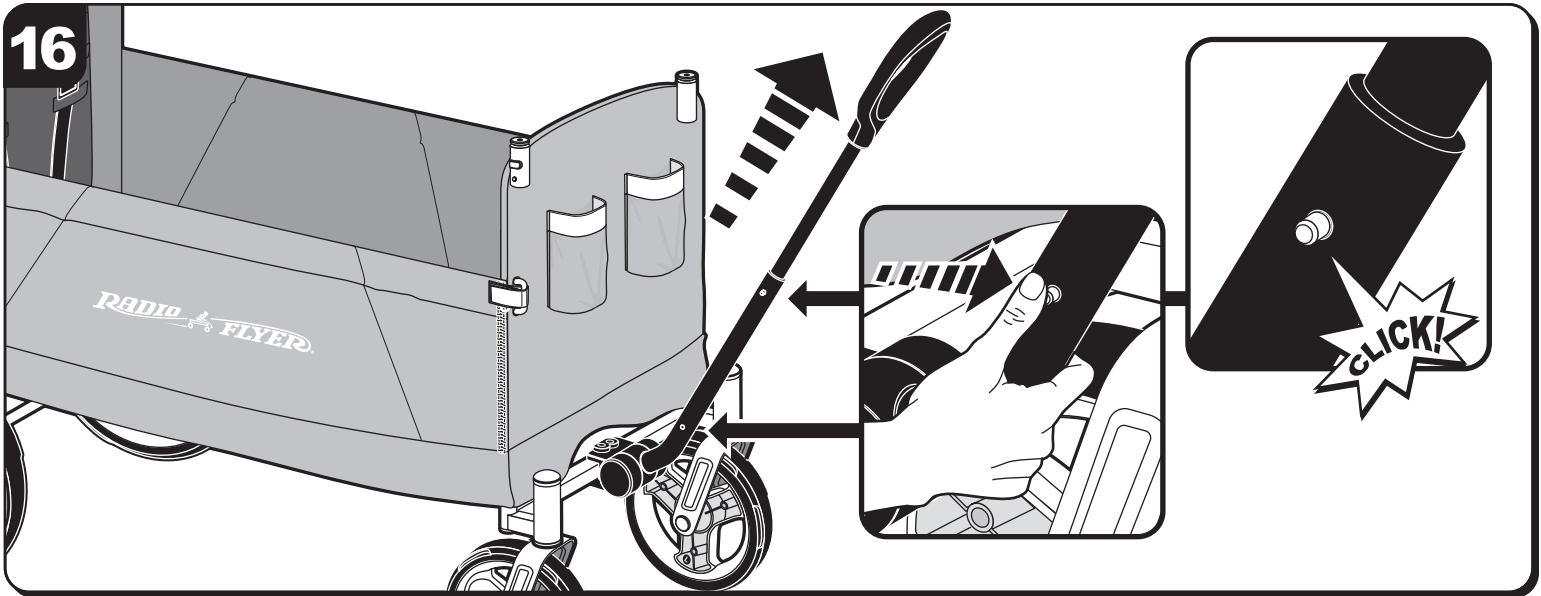

19



CAUTION: Use harness to secure child to wagon seat. **WARNING:** Avoid serious injury from falling or sliding out. Always use 5-point safety harness. Do not leave wagon unattended when children are secured with seat straps.



MISE EN GARDE : Utilisez le harnais pour attacher l'enfant au siège de la voiture. **AVERTISSEMENT :** Évitez les blessures graves provoquées par une chute ou une glissade. Utilisez toujours un harnais de sécurité à 5 points. Ne laissez pas la voiture sans surveillance lorsque des enfants sont attachés avec les courroies du siège.



PRECAUCIÓN: Use el arnés para asegurar al niño al asiento del carro. **ADVERTENCIA:** Evite lesiones graves por caídas o resbalones. Siempre use un arnés de seguridad de 5 puntos. No deje la carretilla descuidada cuando los niños estén asegurados con las correas del asiento.

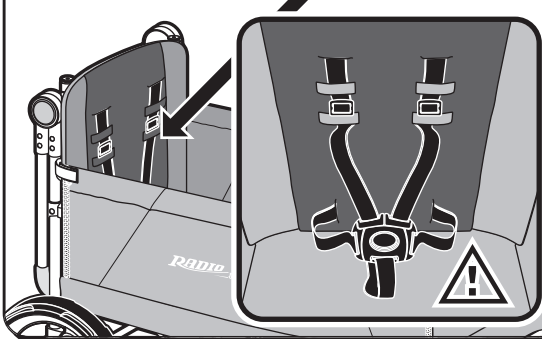

- 3 adjustable strap positions to grow with your child.
- Trois positions de courroie réglables selon la hauteur de votre enfant.
- Tres posiciones de la correa, ajustable al tamaño del niño.

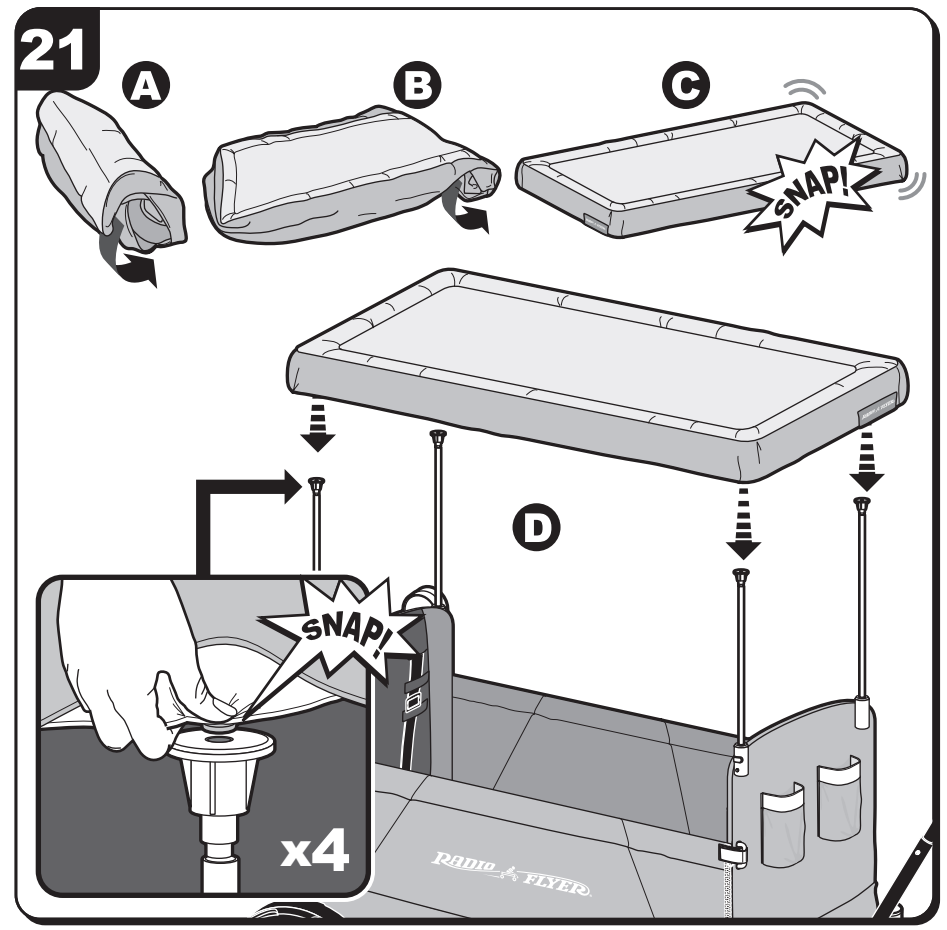
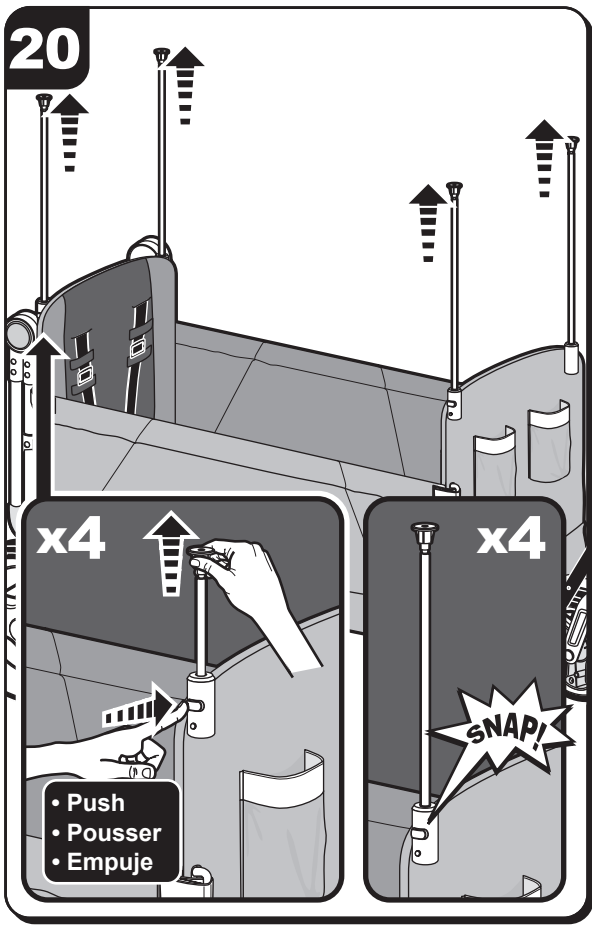
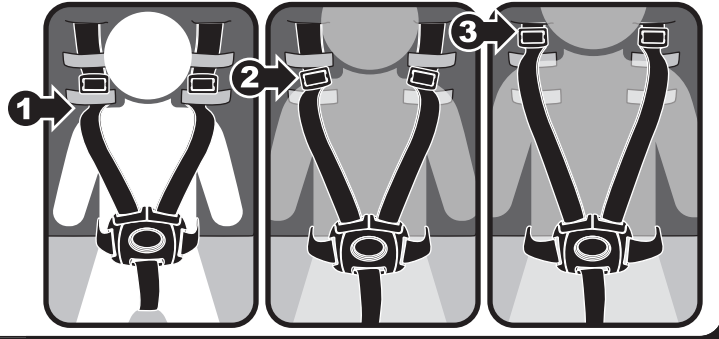

22

- Folding the canopy:
- Pliage de l'auvent pour rangement:
- Pliegue la capota para su almacenamiento:

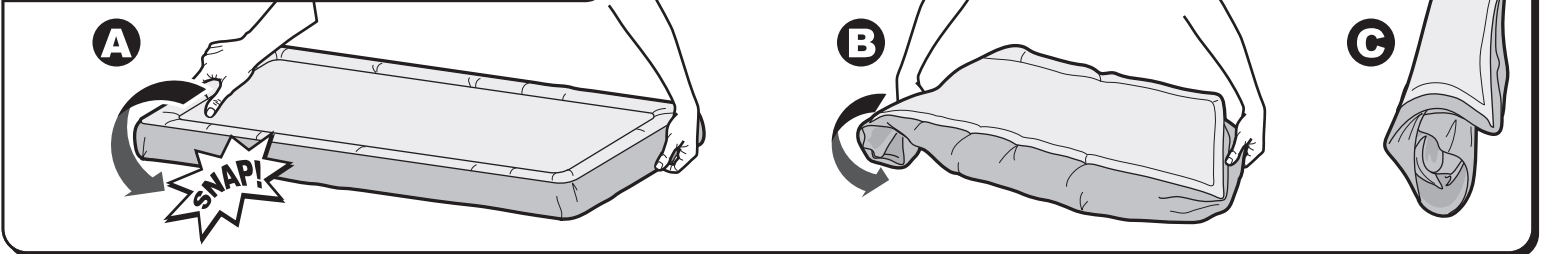

23

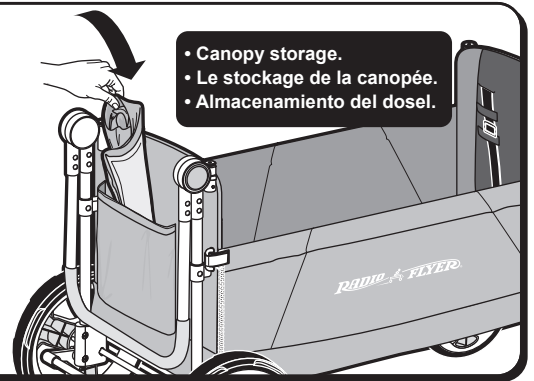
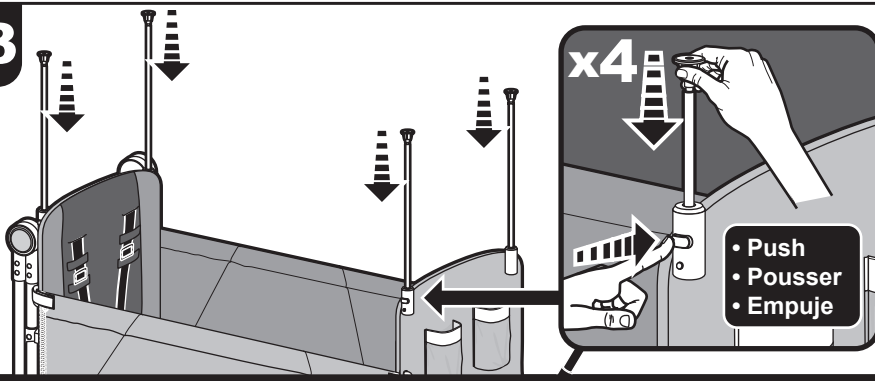

24 • Convert to bench:
 • Convertir en banc:
 • Convertir a la banca:

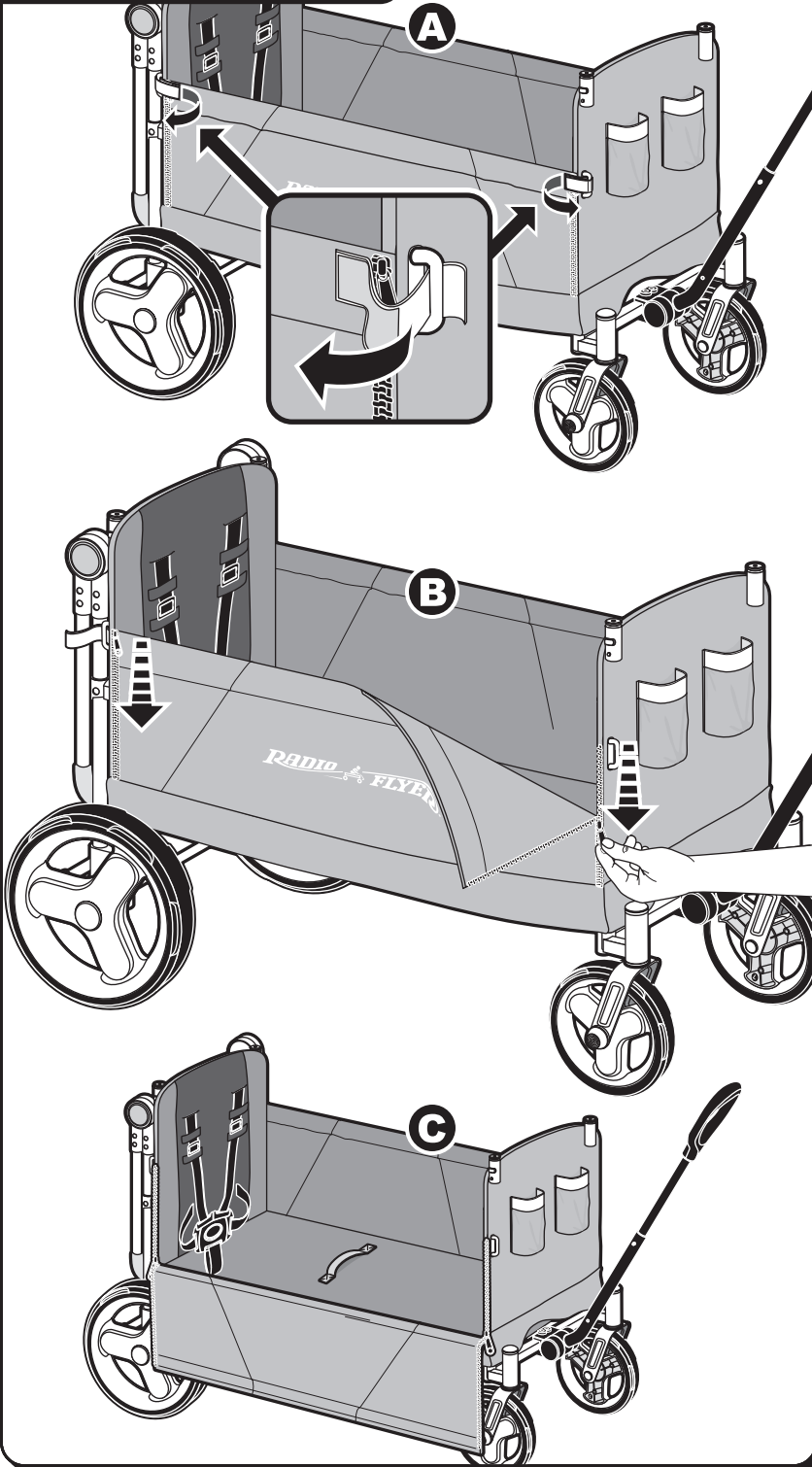

25 • Convert to wagon:
 • Convertir en wagon:
 • Convertir al vagón:

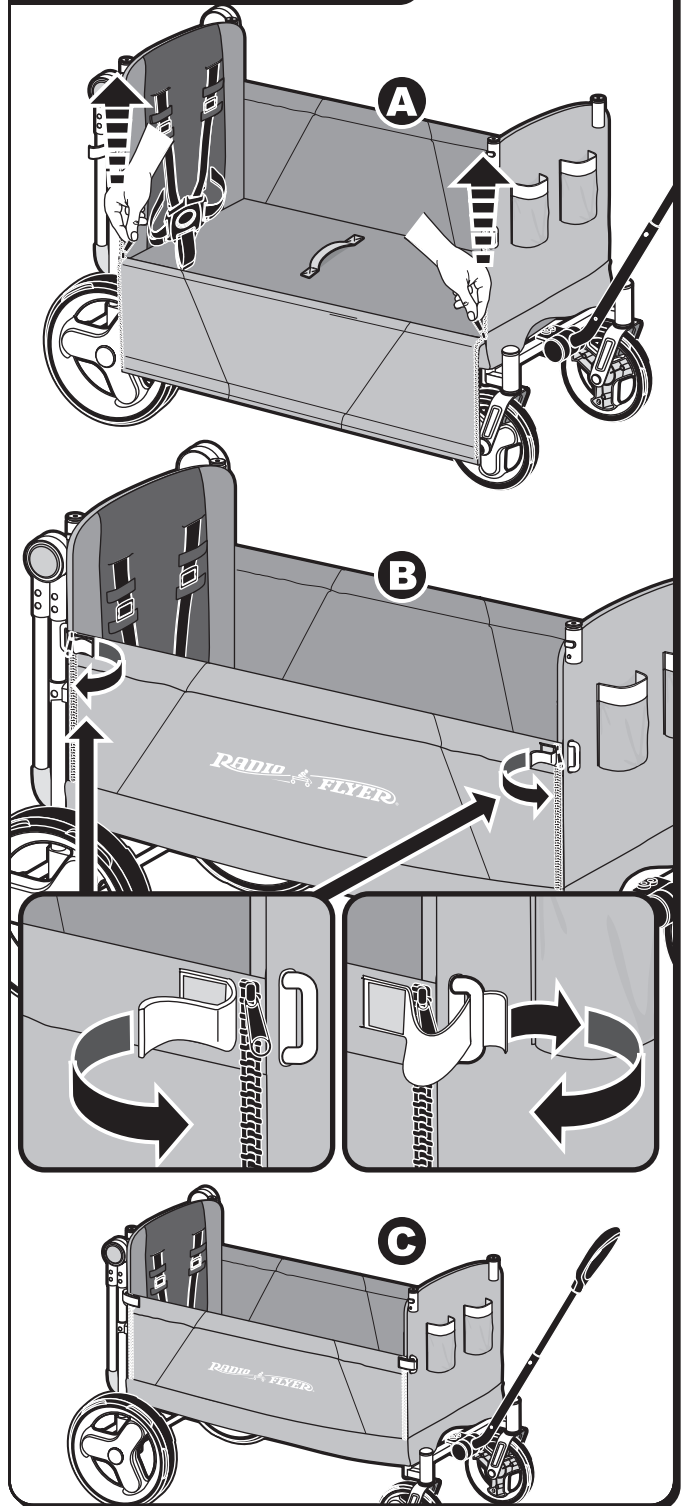

- 26** • For compact storage:
 • Pour un rangement compact:
 • Para un almacenamiento compacto:

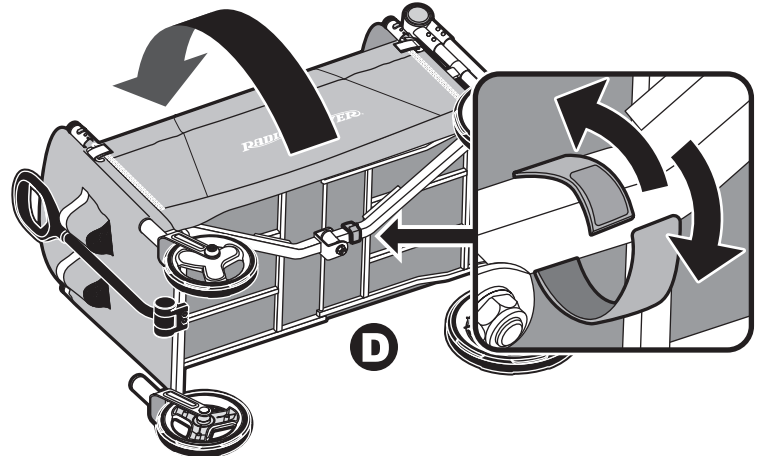
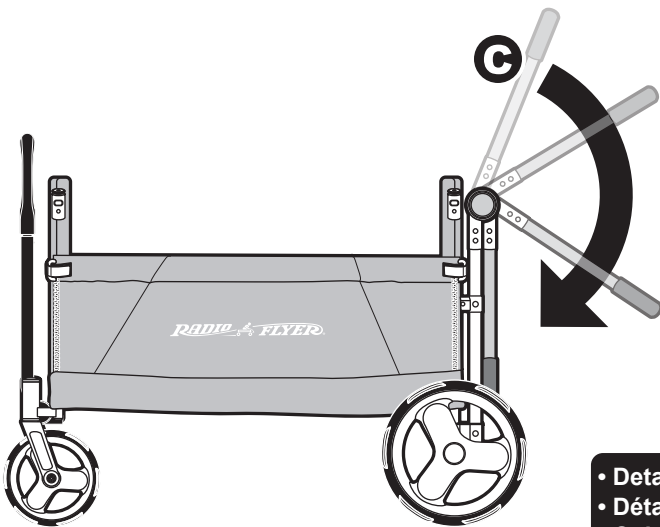
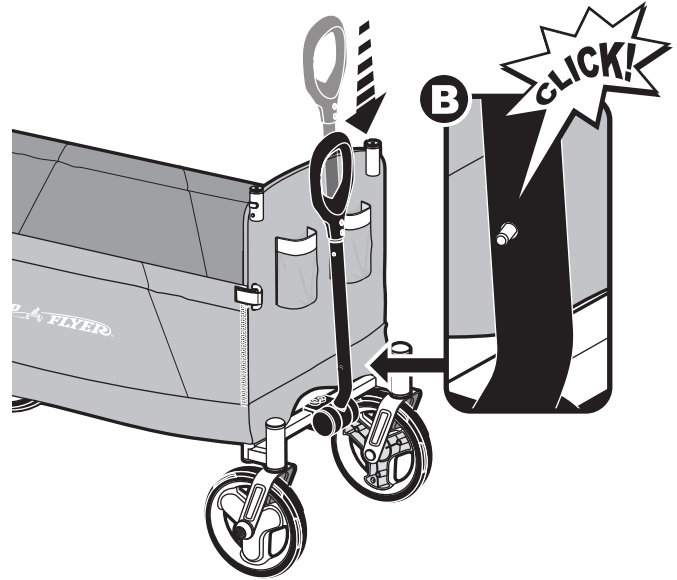
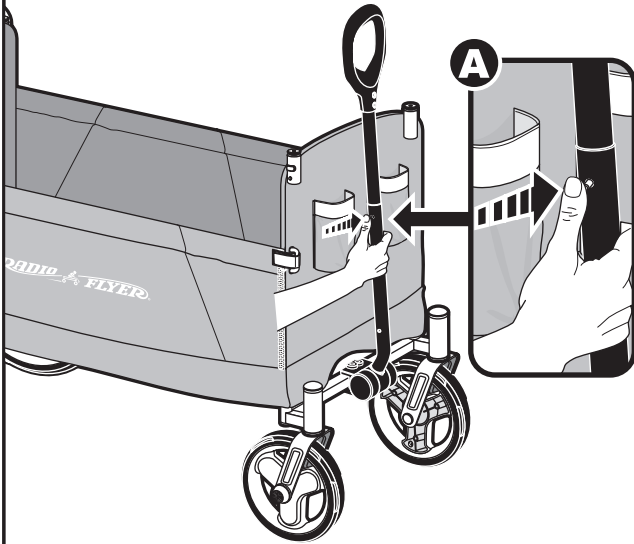

- Detach Velcro strap in order to fold for storage.
- Détachez la courroie en Velcro afin de plier la voiture pour son rangement.
- Coloque la correa de velcro para plegarla y guardarla.

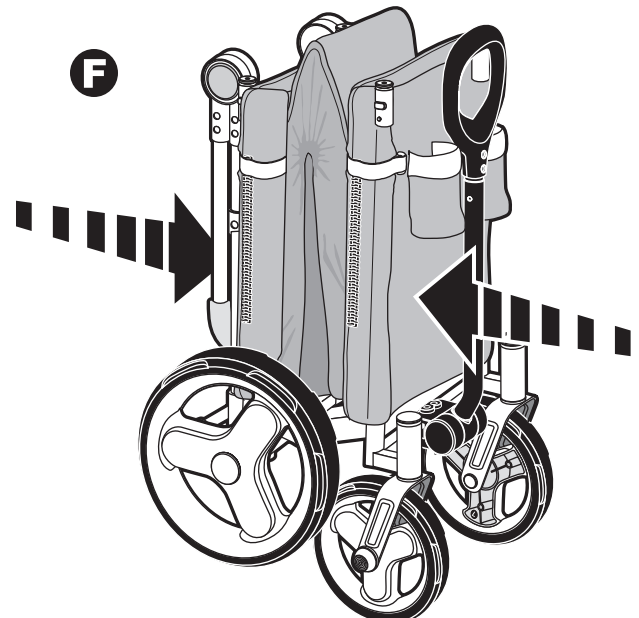
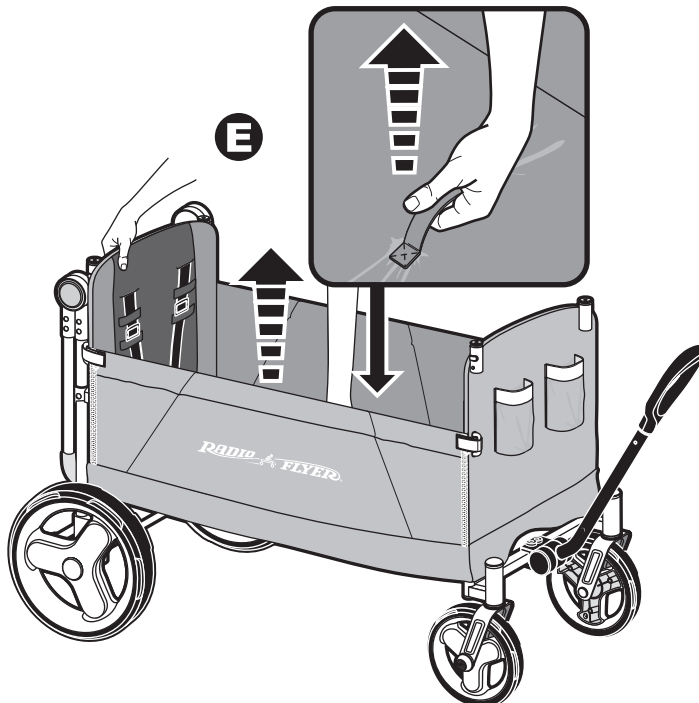

⚠️ WARNING:**TO AVOID SERIOUS INJURY:**

- Never leave child unattended. Continuous adult supervision is required.
- Avoid serious injury from falling or sliding out. Always use 5 pt safety harness.
- To prevent falls or injuries, children must remain seated with their arms and legs inside the wagon while riding.
- Never use near motor vehicles, streets, roadways, alleys, swimming pool areas, hills, steps, sloped driveways, inclines and public highways.
- Apply brake when taking children in or out.
- Only for children 12 months or older.
- Do not exceed maximum weight of 120.0 lb (54.4 kg) or product may become unstable.
- Do not hang items on the handlebar or place them on the canopy as they can tip product over and injure child.
- No more than 2 riders at a time.
- Never ride the wagon outside at night.
- Never use in wet weather.
- Maximum loading capacity of bags are 5.0 lbs. Excessive weight may cause a hazardous or unstable condition.
- Unfold and lock wagon in riding position before use.
- Only adults should fold and unfold the wagon.
- Always take care when folding and unfolding the product to prevent finger entrapment.
- This product is not intended for sleep or laying down. Do not use product as a carriage or bassinet.
- Do not use this product while jogging or running.

⚠️ AVERTISSEMENT:**POUR ÉVITER TOUTE BLESSURE GRAVE:**

- Ne laissez jamais un enfant sans surveillance. Une supervision continue par un adulte est requise.
- Évitez les blessures graves provoquées par une chute ou une glissade. Utilisez toujours un harnais de sécurité à 5 points.
- Pour empêcher les chutes et les blessures, les enfants doivent rester assis les bras et les jambes à l'intérieur de la voiture lors de sa conduite.
- N'utilisez jamais près de véhicules motorisés, rues, routes, allées, zones de piscines, collines, marches, entrées en pente, inclinaisons et autoroutes publiques.
- Appliquez le frein lors de l'entrée ou la sortie d'enfants.
- Seulement pour les enfants de 12 mois et plus.
- Ne dépassez jamais le poids maximal de 54,4 kg (120,0 lb), sinon le produit peut devenir instable.
- Ne suspendez pas des articles sur le guidon, ni ne les placez sur l'auvent, car ils peuvent faire basculer le produit et blesser un enfant.
- Pas plus de deux enfants à la fois.
- N'utilisez jamais la voiture dehors la nuit.
- Ne l'utilisez jamais lorsqu'il pleut.
- La capacité de chargement maximale des sacs est de 2.25 kg (5,0 lb). Le poids excessif peut causer une condition hasardeuse ou instable.
- Dépliez et bloquez la voiture en position de conduite avant son utilisation.
- Seuls des adultes doivent plier et déplier la voiture.
- Veillez toujours à ne pas vous coincer les doigts lors du pliage et du dépliage du produit.
- Ce produit n'est pas conçu pour y dormir ou s'y reposer. N'utilisez pas ce produit comme un chariot ou une couchette.
- N'utilisez pas ce produit tout en joggant ou en courant.
- Laver la surface du tissu avec de l'eau chaude et un savon doux. No pas laver le tissu à la machine.

⚠️ ADVERTENCIA:**PARA EVITAR LESIONES GRAVES:**

- Nunca descuide al niño o niña que lo acompaña. Es necesaria una supervisión constante por parte de un adulto.
- Evite lesiones graves por caídas o resbalones. Siempre use un arnés de seguridad de 5 puntos.
- Para evitar caídas o lesiones, los niños deben permanecer sentados con los brazos y las piernas dentro de la carretilla mientras viajan.
- Nunca lo use cerca de vehículos motorizados, calles, caminos, callejones, áreas de piscinas, colinas, escalones, caminos inclinados, pendientes y carreteras públicas.
- Use el freno al dejar salir o ingresar niños.
- Solo para niños de 12 meses o mayores.
- No exceda el peso máximo de 120.0 lb (54.4 kg) o el producto puede volverse inestable.
- No cuelgue artículos en la barra de agarre ni los coloque en el dosel, ya que pueden voltear el producto y lesionar al niño.
- No más de 2 ocupantes a la vez.
- Nunca use la carretilla por la noche.
- Nunca la use en tiempo húmedo.
- La capacidad máxima de carga de las bolsas es de 2.25 kg (5.0 lb). Exceso de peso es peligroso y puede causar condiciones inestables.
- Despliegue y asegure la carretilla en posición de conducción antes de usar.
- Solo los adultos deben plegar y desplegar la carretilla.
- Siempre tenga cuidado al doblar y desplegar el producto para evitar que los dedos queden atrapados.
- Este producto no está destinado para dormir o acostarse. No utilice el producto como un coche o cuna.
- No utilice este producto mientras trota o corre.

MAINTENANCE INSTRUCTIONS:

- Periodically check hardware and tighten if necessary. Replace worn or broken parts immediately.
- Surface wash fabric with warm water and mild soap. Do not machine wash fabric.

INSTRUCTIONS D'ENTRETIEN:

- Vérifiez périodiquement la quincaillerie et resserrez-la au besoin. Remplacez immédiatement les pièces usées ou brisées.
- Laver la surface du tissu avec de l'eau chaude et un savon doux. No pas laver le tissu à la machine.

INSTRUCCIONES DE MANTENIMIENTO:

- Revise periódicamente la estructura y asegúrela si es necesario. Reemplace inmediatamente las piezas gastadas o rotas.
- Lavar superficie del tejido con agua tibia y jabón suave. No lavar a máquina.