

FLYER™

BY RADIO FLYER

**FLYER™ 20" KIDS' BIKE
OWNER'S MANUAL**

MODELS 840BL, 840R, 840GY, 840T, 840PP

Welcome to the Flyer™ Fleet

Congratulations on your new Flyer™ bike!

The Flyer™ line delivers a high-performance experience for riders of all ages, ranging from micromobility solutions for families to premium wheels for kids. As an extension of the Radio Flyer® brand, Flyer™ products are created with the same beautiful design and quality that has inspired our work for over a century. We hope your new bike offers a fun, sustainable, and convenient way to get out and explore your world.

We can't wait to see where your new ride takes you.

Cheers,

The Radio Flyer Team

Time Flies. Enjoy the Ride.®

ABOUT THIS MANUAL

This owner's manual contains details of your Flyer™ kids' bike including instructions for assembly, operating, and maintenance. To ensure safe use and prevent injury, please carefully read all information in this manual before use. Take time to familiarize yourself with your Flyer™ kids' bike before use.

While this owner's manual is meant to introduce you to your Flyer™ kids' bike, it is impossible to guide owners on every possible scenario when using a bicycle. There are inherent risks using any bicycle and it is the owner's sole responsibility to ensure safe riding. Always take responsibility for you and your child's own safety.

Please keep this manual for future reference. If you have any questions about your bike, contact the Radio Flyer Customer Service Team. Our award-winning service team is committed to providing you with world class support, right from Chicago.

Phone: 1-800-621-7613

Email: customerservice@radioflyer.com

Customer Service Hours: 8am – 5pm CST, Monday through Friday

Flyer™ Service Website: flyer.radioflyer.com/customer-service

TABLE OF CONTENTS

Important Safety Instructions	7
Getting Started	8
Assembly Instructions	8
Fastener Torque Values	15
Accessories	15
Adjusting Bike	16
Riding & Safe Operating Guidelines	20
Ride Safety Checklist	20
Braking and Shifting	22
Maintenance	23
Warranty	24

Component Guide

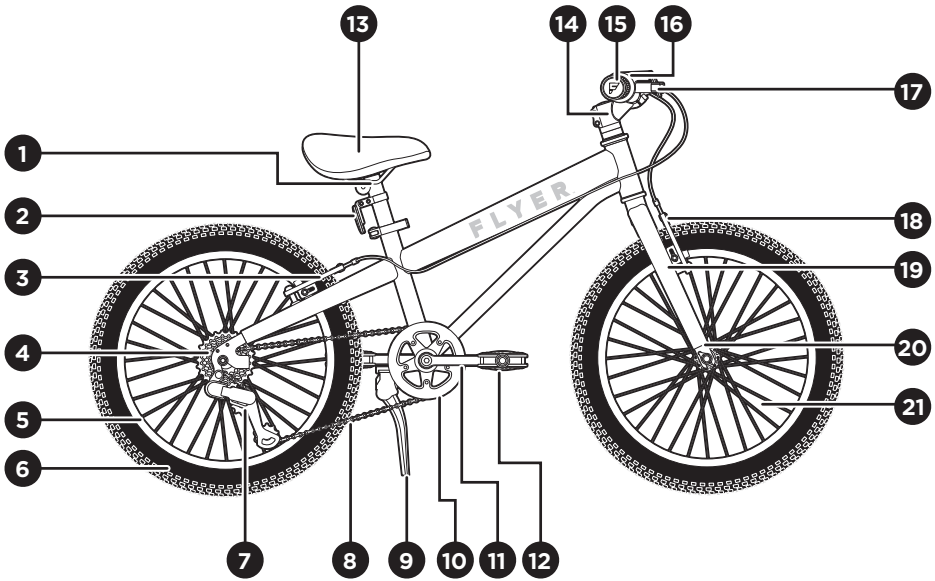

- 1. Seat Post
- 2. Rear Reflector
- 3. Rear Brake
- 4. Cassette
- 5. Rims
- 6. Tires
- 7. Rear Derailleur
- 8. Chain
- 9. Kickstand
- 10. Chainwheel
- 11. Crank

- 12. Pedal
- 13. Saddle
- 14. Stem
- 15. Grips
- 16. Gear Shifter
- 17. Brake Levers
- 18. Front Brake
- 19. Fork
- 20. Front Fork Dropouts
- 21. Spokes

Important Safety Instructions

SAFETY WARNINGS



WARNING! When using this product, basic precautions should always be followed including the following:

- Read all safety warnings and instructions before using the product. Failure to follow warnings and instructions may result in serious injury or death.
- A helmet should be worn at all times when riding the bike. Ensure that the rider of the bike has a helmet that has been fit properly.
- Do not put fingers or hands near spokes or moving parts.
- Always ensure riders have the physical coordination and skill to navigate the bicycle safely while managing road conditions, traffic and adhering to all laws for bicycle use.
- Regularly check brake wear and performance, tire pressure, steering performance, and rim wear (see Maintenance Instructions).
- Avoid riding the bike in wet or icy conditions. If riding in wet or icy conditions, the braking distance of the bike will be increased. Ride more slowly and cautiously in these conditions.
- Avoid riding the bike at night and in the dark. If riding in the dark, use a bike headlight (not included).
- This bike is not suitable for the fitting of a luggage carrier, child seat, and/or bicycle trailer.
- Please check local laws to confirm legal requirements for using your bike. This Flyer™ bike is meant for paved roads and sidewalks, not off-road conditions.
- This Flyer™ 20" Kids' Bike is intended for riders from 45"-52" tall.

SAVE THESE INSTRUCTIONS

Getting Started

ASSEMBLY INSTRUCTIONS

The following steps provide a general overview of the assembly process for your bike. It is recommended to consult a professional bicycle mechanic for assistance with the bike's assembly, maintenance, and repair.

Visit flyer.radioflyer.com or contact customerservice@radioflyer.com for additional assistance assembling, using, repairing or maintaining your bike.



⚠ WARNING! Incorrect assembly, maintenance, or use of your Flyer™ kids' bike can cause component failure, loss of control, serious injury, or death. Please note, the assembly and first fit of your Flyer™ kids' bike require special tools and mechanical skills. It is highly recommended that the assembly and adjustment are completed by a reputable bicycle mechanic when possible.

The following items are required for assembly:

- 5mm allen wrench (included)
- 6mm allen wrench (included)
- 15mm open-ended wrench (included)
- Scissors or flat-sided cutters
- Philips screwdriver
- Tire pump
- Pedal grease (recommended)
- Torque wrench (recommended)

Step 1: Unpack your bike

Remove the bike from the outer carton and set it on a flat, clean surface. Place the bike upright, resting on the front fork dropouts and rear wheel. Remove all protective packaging material and carefully cut all zip-ties to avoid damaging the paint. Verify that you have all of the components listed below. Contact Radio Flyer Customer Service if any components are missing.

- Frame, Fork, and Rear Wheel
- Handlebars
- Front Wheel
- Saddle and Seat Post
- Pedals
- Reflectors
- Tool Kit

Step 2: Install the handlebar

- A. Using the provided 6mm allen wrench, loosen the two bolts and remove the stem faceplate.
- B. Align and center the handlebar in the stem. Check that the handlebar orientation matches the image below and that the cables are not twisted.
- C. Reinstall the stem faceplate and two bolts using the 6mm allen wrench. Evenly tighten the bolts to 10 to 12 Nm using a torque wrench.

Note: Complete assembly of the bike per the steps below. The handlebar angle can be adjusted as needed based on rider preference. Always re-tighten bolts to the specified torque values prior to riding.

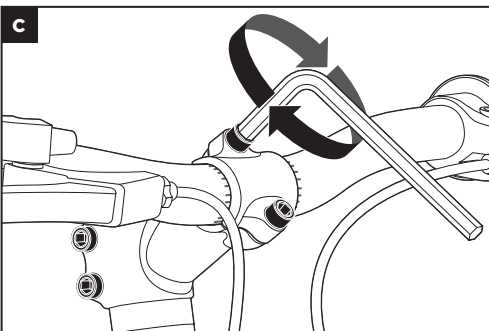
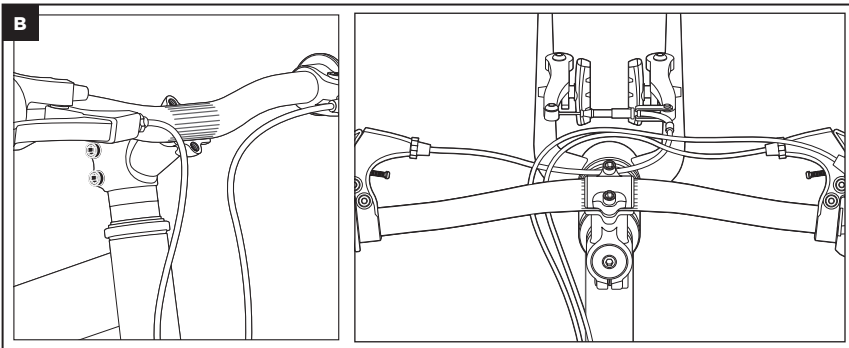
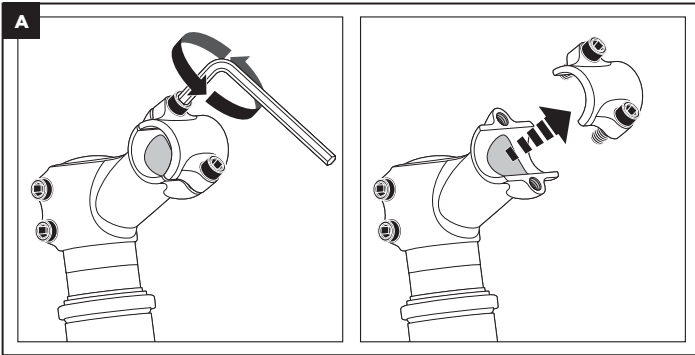

Step 3: Install the front wheel

The bike is shipped with a spacer installed in the fork dropouts to prevent damage during shipment. Prior to installing the front wheel, this spacer must be removed. Once removed, the spacer may be discarded.

- A. Squeeze the brake arms together and move the rotating metal linkage downwards to detach the two side. Remove the nuts and washers from both sides of the front wheel.
- B. Align the wheel to the fork so that the fork dropouts rest on the axle. Ensure the fork is fully seated on the axle, the wheel is centered on the fork, and the brake arms are facing forwards.
- C. Place the washers over the threaded ends of the front wheel hub, inserting the bent tab into the hole on the fork dropouts. Tighten the nuts on each side of the front hub to 28 to 32 Nm.
- D. Press the brake arms together and attach the two sides using the rotating metal linkage. Tune the brakes to ensure ideal performance (see Maintenance Instructions).

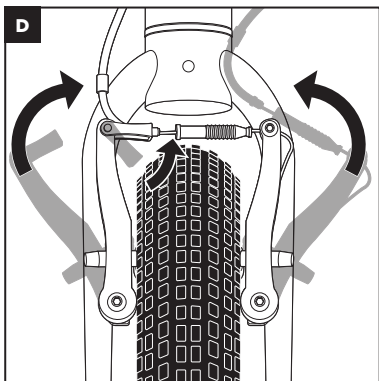
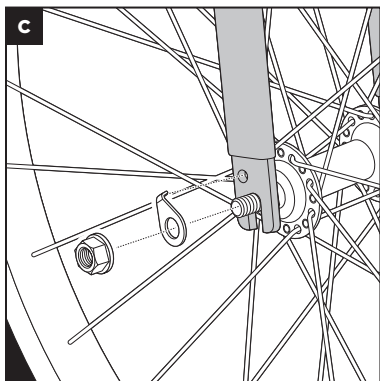
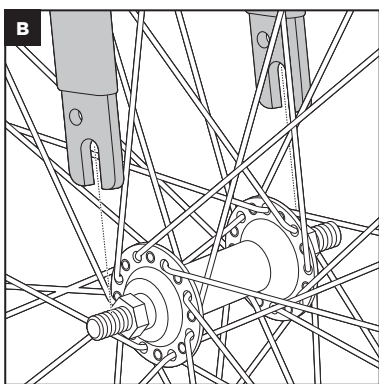
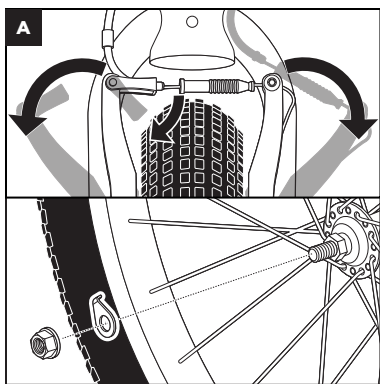

Step 4: Install the saddle

- A. Deploy the kickstand to allow the bike to stand freely.
- B. Open the quick-release lever and insert the seat post into the seat tube.
- C. Position the seat post at an appropriate height for the rider. See page 16.
- D. Tighten the adjustment nut on the quick-release clamp, then close the quick-release lever.

Note: Closing the quick release lever should require enough pressure that it leaves an imprint in your hand. If it's too easy or too difficult to close, adjust the lever tension by turning the adjustment nut opposite the quick release lever.

⚠ WARNING! The seat post must be inserted to the minimum insertion mark. Do not raise the seat post beyond the minimum insertion marking on the seat post tube. If the seat post is not inserted properly, the seat may be loose which can lead to serious injury or death. After assembly, reflectors should be visible and not obscured by the rear wheel.

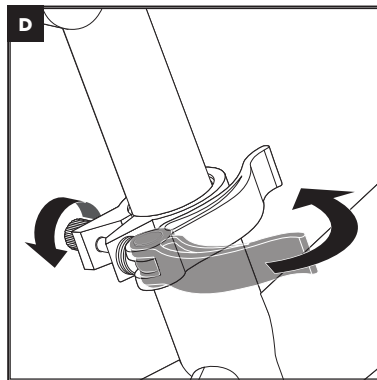
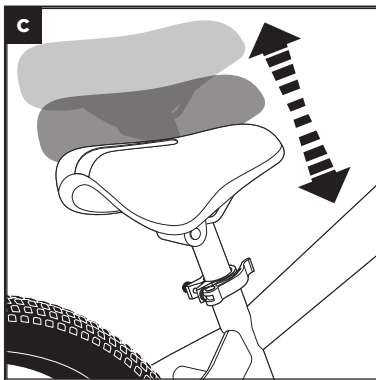
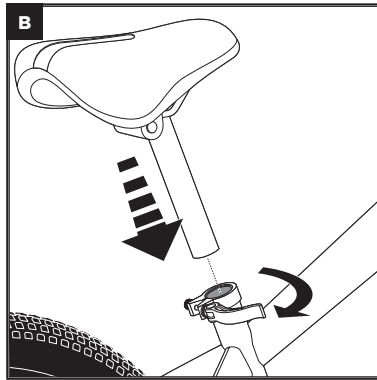
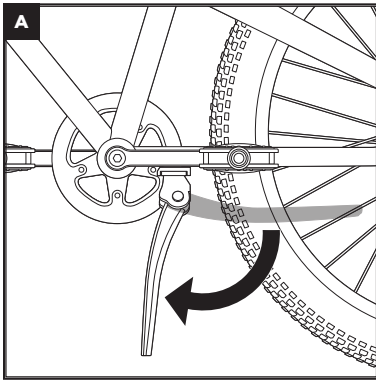

Step 5: Install pedals

- A. Identify the right and left pedals before assembling. The different pedals are specified with stickers on their surface, as well as an engraving on the end of the threaded portion of the pedal. The right pedal corresponds to where the rider's right foot is during use.
- B. Install the right pedal to the right side crank arm by turning the axle clockwise by hand.
- C. Install the left pedal to the left side crank arm by turning the axle counter-clockwise by hand.
- D. Use the provided 15mm wrench to tighten the right pedal onto the crank arm. Torque the right pedal to 35 to 40 Nm using a torque wrench.
- E. Use the provided 15mm wrench to tighten the left pedal onto the crank arm. Torque the left pedal to 35 to 40 Nm using a torque wrench.

Note: We recommend applying pedal grease to the threads prior to installation

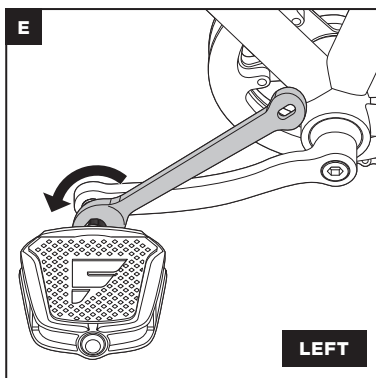
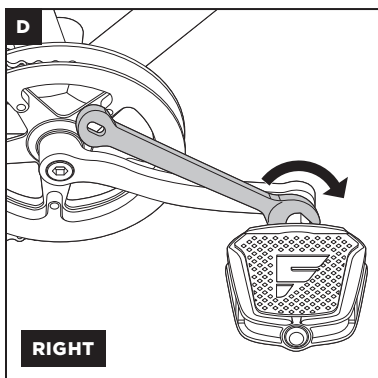
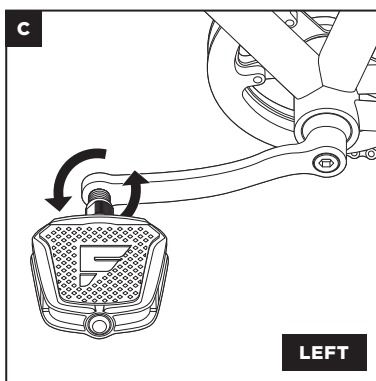
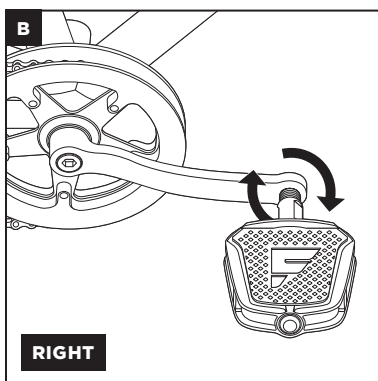
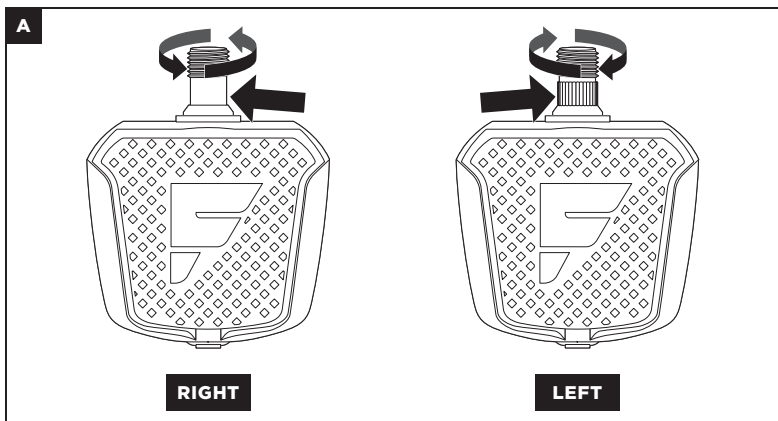

Step 6: Install the reflectors

- A. Use a Phillips head screwdriver to remove the screw from the mounting portion of each reflector.
- B. Mount the white reflector to the front of the handlebar. Tighten down the mounting screw to secure the reflector.
- C. Mount the red reflector to the back of the seat post. Tighten down the mounting screw to secure the reflector. The face of the rear reflector is positioned at an angle to the mounting bracket. When installing, ensure the face of the reflector is installed so as to be facing directly backwards, not tilted downwards.

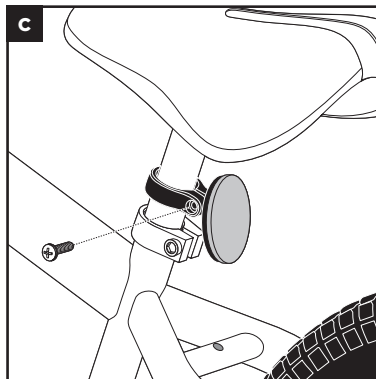
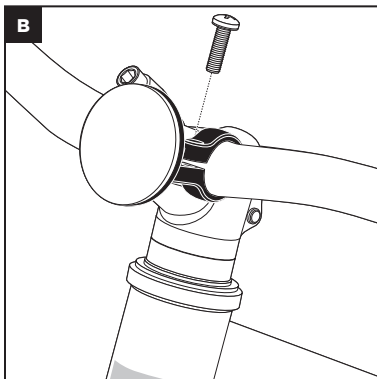
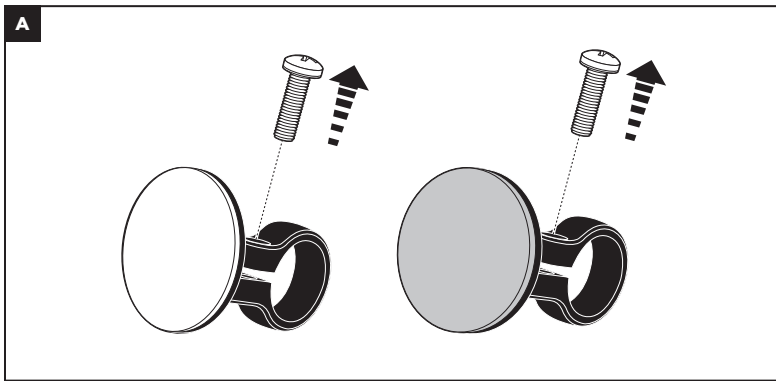

Step 7: Check fastener torque values

Area of Bike	Hardware	Torque (Nm)
Handlebar	Stem Clamp Bolts	18 to 20
	Brake Lever Clamp Bolts	7 to 9
	Stem Faceplate Bolts	10 to 12
Seat Post	Quick Release Level (closed)	13 to 15
	Seat Mounting Bolts	8 to 12
Kickstand	Kickstand Bolt	18 to 22
Front/Rear Brakes	Brake Cable Pinch Bolt	7 to 9
	Brake Pad Threaded Stud	10 to 12
	V Brake to Frame	10 to 12
Front/Rear Dropout	Rear Axle Nuts	28 to 32
	Front Axle Nuts	28 to 32
Bottom Bracket	Crank Arm Bolt	38 to 42
	Pedal into Crank Arm	35 to 40
	Chain Ring Bolts	4 to 6

Step 8: Inflate tires to 45 psi



 **WARNING!** It is important to maintain proper air pressure in the tires while riding. Do not over inflate or under inflate the tires. Overinflated tires may burst. Inflate the tires using an air source with a pressure gauge to avoid overinflation. Underinflated tires may impair the control of the bike and cause a safety hazard.

ACCESSORIES

Radio Flyer carries a full line of accessories to enhance the usability of your Flyer™ kids' bike. Please refer to the instruction sheets provided with each accessory to ensure proper assembly. Visit flyer.radioflyer.com or contact customerservice@radioflyer.com for additional assistance assembling, using, or repairing your accessories.

 **WARNING!** Incorrect installation of accessories can cause damage to the bike frame, loss of control, serious injury, or death.

ADJUSTING SEAT HEIGHT

The seat height should be set based on the rider's personal preference. The initial seat position can be set by first placing the ball of the rider's foot on the pedal with the crank arm in its lowest position. In this position, the rider's leg should be almost fully extended with a slight bend in your knee. The proper seat position is important to avoid strain and potential injury during riding. Consult a trusted, reputable bike mechanic or contact Radio Flyer customer service for questions related to the seat position and fit of the bike.

⚠ WARNING! The seat post must be inserted to the minimum insertion mark. Do not raise the seat post beyond the minimum insertion marking on the seat post tube. If the seat post is not inserted properly, the seat may be loose which can lead to serious injury or death. After assembly, reflectors should be visible and not obscured by the rear wheel.

- A. Open the quick release lever located under the saddle. Rotate the lever fully open to allow the seat post to slide easily.
- B. Move the seat up and down by sliding the seat post in or out of the seat tube. Set the saddle to the desired height based on rider preference. Ensure that the seat post does not extend beyond the "minimum seat post insertion" markings on the seat post.
- C. Close the quick release lever fully against the seat post tube. This should take some force to ensure the seat post will stay firmly in place while riding.

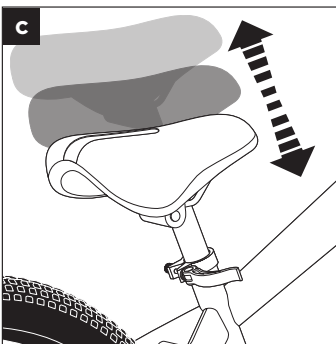
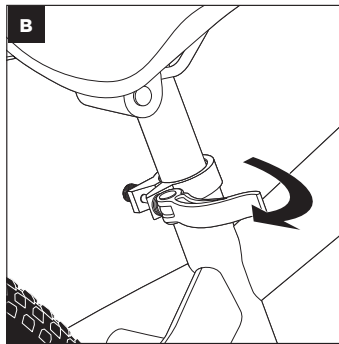
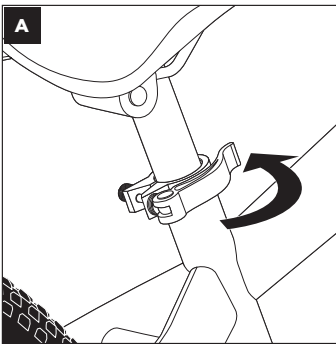

ADJUSTING HANDLEBAR ROTATIONAL POSITION

Following the initial assembly of the handlebar, the handlebar rotational position should be adjusted for the rider. Ensuring that the handgrips and brake levers are in the correct position will avoid any strain or discomfort while riding.

- A. Using the provided 6mm allen wrench, loosen the two stem faceplate bolts.
- B. Rotate the handlebar until the preferred position is achieved checking to ensure the handlebar is centered left-to-right within the stem faceplate.
- C. Retighten the two stem faceplate bolts using the 6mm allen wrench. Evenly tighten the bolts to 10 to 12 Nm using a torque wrench.

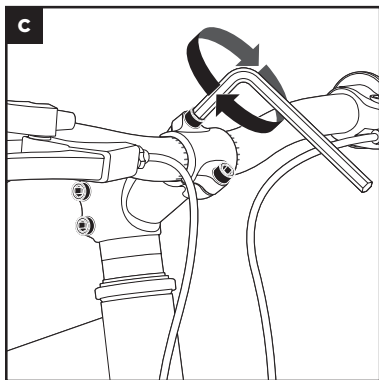
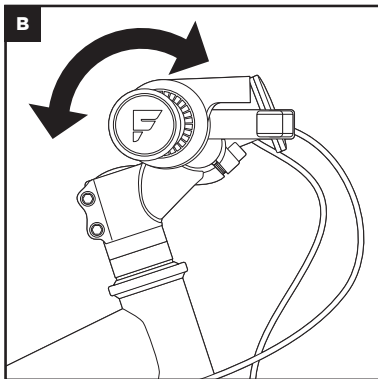
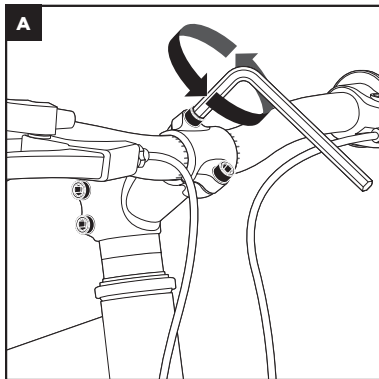

⚠ WARNING! The stem on your Flyer™ kids' bike comes factory assembled to the front fork, and does not need to be removed to adjust the handlebars. If the stem is loosened or removed from the fork, care must be taken during re-assembly to avoid damaging the stem-to-fork connection. Overtightening the stem clamp bolts can damage the stem-to-fork assembly, which can lead to risk of injury. To avoid overtightening, use a torque wrench to tighten the stem clamp bolts to 18 to 20 Nm.

ADJUSTING REAR DERAILLEUR AND SHIFTER

If the shifting system of the bike is skipping gears during shifting or cannot shift into all 7 gears, you may need to adjust the rear derailleur. If the problem began occurring after an impact or other damage to the rear derailleur, bring your bike to a certified and reputable bike mechanic.

- A. The upper limit of the rear derailleur sets the location of the derailleur in gear 7 (smallest sprocket on rear cassette). In order to adjust the upper limit, first shift into gear 7. Next, adjust the indicated screw (1, step C) until the two sprockets of the derailleur are in-line with the smallest sprocket of the cassette.
- B. The lower limit of the rear derailleur sets the location of the derailleur in gear 1 (largest sprocket on rear cassette). In order to adjust the lower limit, first shift into gear 1. Next, adjust the indicated screw (2, step C) until the two sprockets of the derailleur are in-line with the largest sprocket of the cassette.
- C. Adjusting the indexing. Using the twist shifter on the handlebars, shift through all 7 gears. If the chain does not jump to the indicated sprocket during shifting, the cable tension should be increased by loosening the adjustment screw on the derailleur (3). If the chain is skipping over multiple sprockets during one shift, decrease the cable tension by tightening the adjustment screw (3).

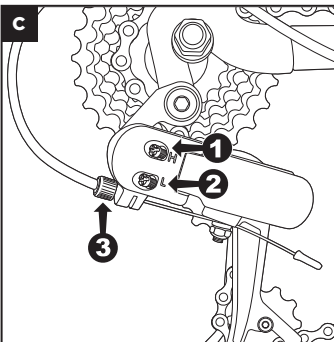
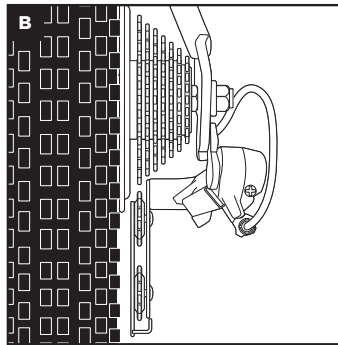
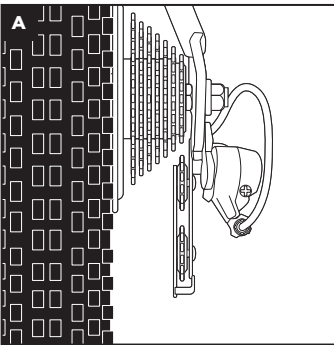

ADJUSTING FRONT AND REAR BRAKES

For safety and ideal performance, the front and rear brakes should be tuned before riding the bike. Brake pads should be regularly checked for wear.

- A. Disengage the brakes using the rotating metal linkage (1). Use the included 5mm allen wrench to loosen the nut behind the brake pad (2). Press the brake arm in towards the wheel, and adjust the position of the pad until it is aligned with the top edge of the rim. The brake pad should not be contacting the tire. Tighten the brake pad nut to lock in the position. Repeat for other side.
- B. Tighten the barrel adjuster (3) on the hand brake fully by turning counterclockwise. Reattach the brake arms and loosen the barrel adjuster until the brake pads contact the rim when the hand brake is depressed halfway.
- C. Ensure that the spacing between the brake pads and the rim is even on both side. Use a Phillips head screwdriver to tighten the pad tension screw (4) in order to move the brake pad away from the rim. Loosen to move the brake pad closer.

⚠ WARNING! Check brake pads regularly for wear. If the brake pads are worn, have reduced performance, or are squeaking/vibrating, they should be checked and serviced by a certified and reputable bike mechanic.

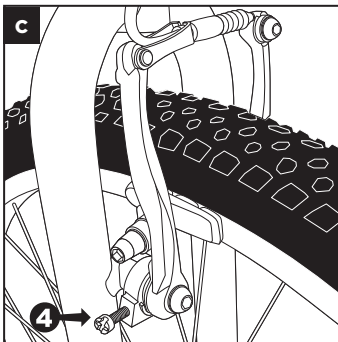
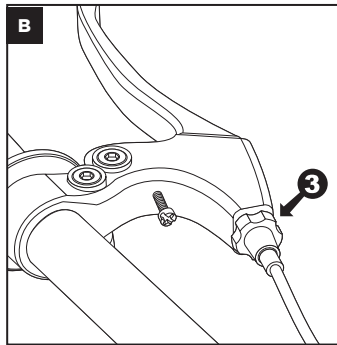
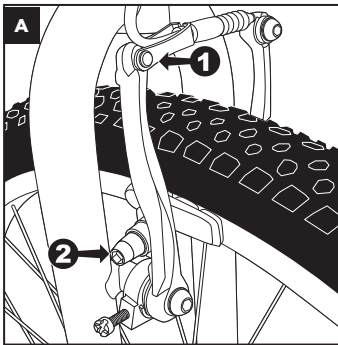

Riding & Safe Operating Guidelines

It is the owner's sole responsibility to ensure safe riding. Among other things:

- Always have the rider obey road and traffic laws as applicable in your local area.
- Always have the rider wear a helmet that meets the US CPSC standard. Wearing a helmet can prevent head injuries.
- After a crash or an incident, do not ride the bike until you have a certified and reputable bike mechanic inspect the bike to ensure proper function of the bike and all its components.
- It is recommended not to ride at night or in wet weather. Ride at night and in wet weather only if necessary.
- If it is unavoidable to ride at night or in wet weather:
 - Wear reflective or light-colored clothing
 - Ride slowly with caution
 - Use a bike headlight (not included)

Before each ride, complete the Ride Safety Checklist:

Component	Steps
Torque Values	<ul style="list-style-type: none">• Reference the torque chart in assembly step 10 to check the torque on all fasteners listed.
Brakes	<ul style="list-style-type: none">• Verify the front and rear brakes function properly.• Check brake cables to confirm there is no wear or deterioration and they are properly lubricated and tensioned.• Check brake pads to ensure they are not over-worn.• Ensure the lever system is secured to the handlebar (torque: 7 to 9 Nm).
Tires	<ul style="list-style-type: none">• Confirm the tires are inflated to 45 PSI.• Check tires for leaks, signs of wear, tread degradation, or other compromising damage.
Wheels	<ul style="list-style-type: none">• Verify wheel spokes are tight on both ends with no bending.• Ensure tires and rims rotate straight without wobble.• Confirm the rear wheel axle nuts are tight and the rear wheel is properly secured (torque: 28 to 32 Nm)• Confirm the front wheel is properly secured.
Rims	<ul style="list-style-type: none">• Check that engraved channel in rim is visible. Over time, this channel will become shallower, and eventually will disappear.• If the channel has disappeared, replace rims immediately. Excessive wear can reduce braking performance, and result in full wheel failure in extreme cases.

Seat	<ul style="list-style-type: none"> • Ensure the seat is securely connected to the bike and the seat cannot be moved. • Confirm the clamp adjustment lever is fully tightened and locked. • Verify the seat is properly adjusted to fit the rider's height. • Confirm that the seat is securely fastened to the post (torque: 8 to 12 Nm).
Handlebar	<ul style="list-style-type: none"> • Confirm the handlebar always aligns with fork when moving in desired direction and both parts turn in unison. • Secure the front wheel or fork, preventing it from turning. Apply approximately 30 lbs of force to one of the handlebar grips. The handlebar should not rotate independently from the front wheel or fork. • Confirm the stem clamp bolts are tightened to 18 to 20 Nm and the stem faceplate bolts are tightened to 10 to 12 Nm.
Chain	<ul style="list-style-type: none"> • Ensure the chain is properly lubricated and runs smoothly. • After using in rough weather conditions such as rain, snow, or other severe weather, verify that chain and links are clean and undamaged.
Bearings	<ul style="list-style-type: none"> • Verify all bearings are lubricated and run smoothly with no unnatural sounds such as grinding or rattling. • Check the bearings in the headset assembly, pedals and bottom bracket, and the rear wheel.
Cranks & Pedals	<ul style="list-style-type: none"> • Confirm pedals are tightly secured to the cranks (torque: 35 to 40 Nm) and the crank is tightly secured to the bottom bracket spindle (torque: 38 to 42 Nm). • Verify cranks are parallel to the downtube and not bent.
Frame & Fork	<ul style="list-style-type: none"> • Confirm there is no damage or bending to the front fork and frame and that fork is parallel with the front tire.
Control Cables	<ul style="list-style-type: none"> • Confirm all cables are routed away from moving parts and allow the headset to rotate freely. • Confirm cables are undamaged and free of debris and liquids.
Accessories	<ul style="list-style-type: none"> • Ensure that any loads or accessories do not interfere with moving parts. • Tighten and secure all accessories and accessory components. • Ensure rider is wearing a helmet and the helmet is not damaged.
Reflectors	<ul style="list-style-type: none"> • Verify reflectors are adjusted and outward facing before all rides. • Ensure that loads or accessories do not interfere with reflectors.

CARRYING LOADS

The total maximum payload capacity of this Flyer™ bike is 155lbs (70kg). This includes the weight of the rider, as well as any, cargo, accessories etc.

Maximum payload capacity: 155lbs (70kg)

Maximum total weight (bike and payload): 179lbs (81kg)

Always reference the maximum weight capacity of any accessories used as well.

 **WARNING!** Adding loads to the product may impact stability. Always follow the weight limit guidelines. It is the rider's responsibility to ensure any cargo or passenger weight will not impact the rider's ability to safely use the product.

USING FRONT AND REAR BRAKES

The Flyer™ 20" Kids' Bike is fitted with linear pull brakes on the front and rear wheels. To activate the front brake, squeeze the left brake lever. To activate the rear brake, squeeze the right brake lever. Always brake with both brakes simultaneously.

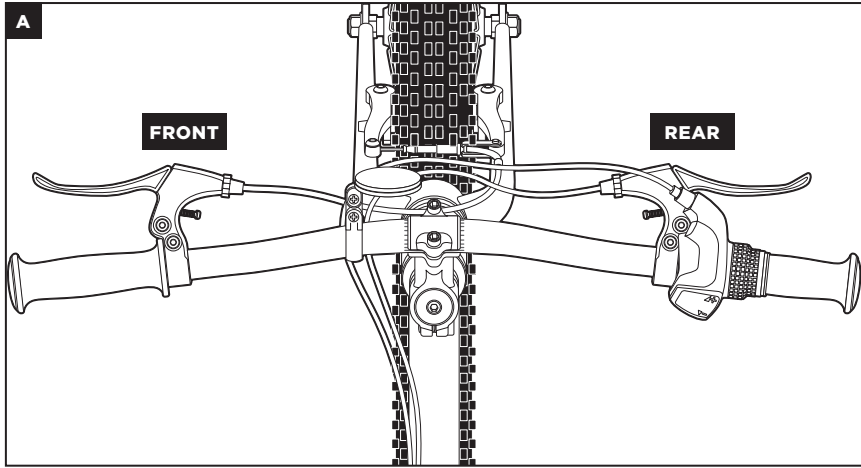

USING GEAR SHIFTER

The Flyer™ 20" Kids' Bike is fitted with a 7-speed gear shifter. In order to shift gears, twist the shifter located on the right of the handlebars. Twisting forwards away from the rider will result in shifting to a higher gear. Twisting backwards towards the rider will shift to a lower gear. Gears can only be shifted when pedaling the bike. Use lower gears to facilitate starting the movement of the bike, and for climbing hills. Use higher gears as you increase the speed of the bike.

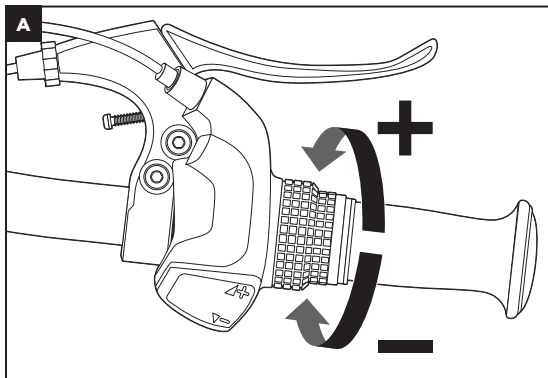

Maintenance

Always have a certified and reputable bike mechanic complete a tune-up on your bike after your first 50-100mi. Regular tune-ups and inspections are critical to ensuring your bike stays in safe condition.

For more information on recommended maintenance intervals please visit:



- After a crash or an incident, do not ride the bike until you have a certified and reputable bike mechanic inspect the bike to ensure proper function bike and all its components.
- Any changes to the Flyer™ kids' bike that are not specifically approved by Radio Flyer Inc. could cause unsafe riding conditions and may void your warranty.

CLEANING

- Do not spray with water or use a pressure washer to clean your bike. Do not immerse this product in water or liquid.
- Do not clean the bike with acids or solvents.
- Wipe clean with a damp cloth. If needed, use a mild soap, like dish detergent.

Warranty

For information on your Flyer™ 20" Kids' Bike's warranty please visit:



