



"Duke" Interactive Spring Horse

model/modèle/modelo #382

For ages over 2 to 6 years. Max weight 60.0 lbs (27.2 kg).
 Pour enfants de 2 à 6 ans. Charge maximale 27.2 kg (60.0 livres).
 Para los niños 2 a 6 años. Peso máximo 27.2 kg (60.0 lbs).



Register this product at www.radioflyer.com/register
 for a chance to win a Free Radio Flyer product!
 (One winner selected every month!)

Thank you for your purchase. If you have any questions or comments,
 please visit the customer service section of our website:

Merci d'avoir acheté notre produit. Si vous avez des questions ou
 commentaires, veuillez référer notre site web dans la section de service à
 la clientèle:

Gracias por su compra. Si tiene preguntas o comentarios por favor visite
 la sección, servicio al cliente de nuestro website:

www.radioflyer.com

Or phone / ou composez le / o llame al 1-800-621-7613
 Available weekdays 8:00 a.m. to 5:00 p.m. CST.
 Please keep this sheet for future reference.
 Disponible sur semaine de 8:00 heures 17:00 heures.
 Veuillez garder cette feuille comme référence.
 De lunes a viernes de 8:00 a.m. a 5:00 p.m. CST.
 Por favor retenga esta copia para futura referencia.

Radio Flyer Inc. / 6515 West Grand Ave. / Chicago, IL 60707
 phone: 1-800-621-7613

The Original Little Red Wagon™ - Since 1917

1

Tools Required:
 Outils nécessaires:
 Herramientas
 necesarias:



Tools Included:
 Outils fournis:
 Herramientas
 incluidas:
 101967 (x1)



2

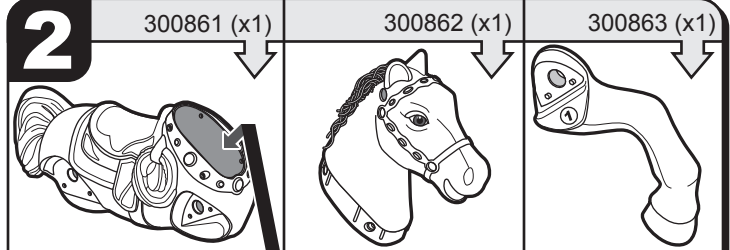

• Be sure to check for components packed inside horse body.
 • Assurez-vous de rechercher les composants emballés dans le corps du cheval.
 • Asegúrese de revisar los componentes empacados dentro del cuerpo del caballo.

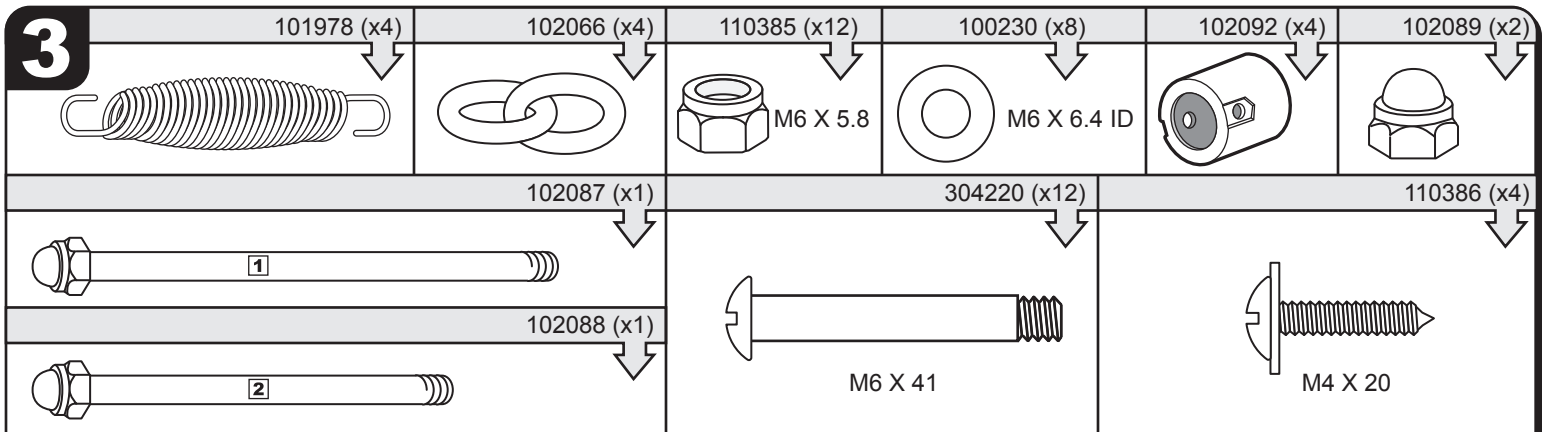
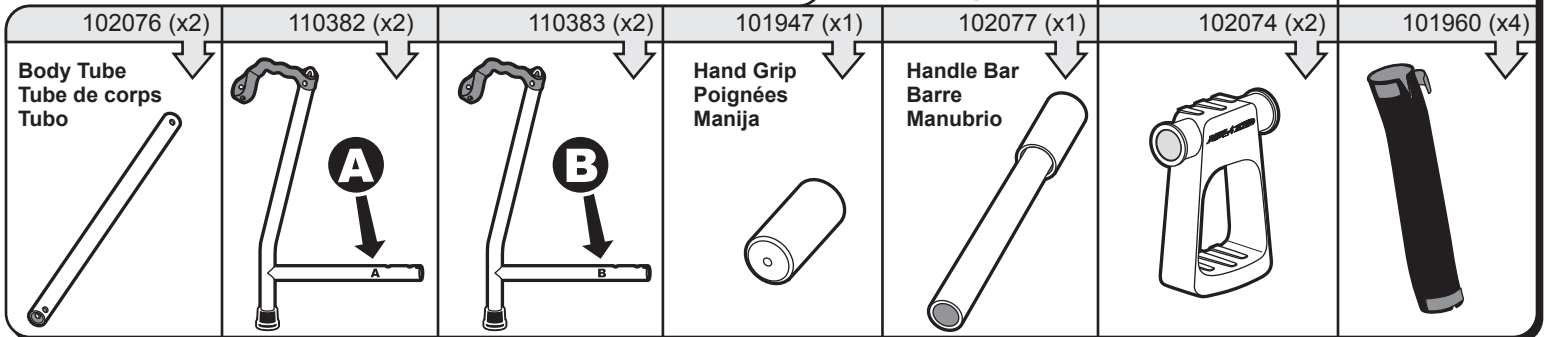
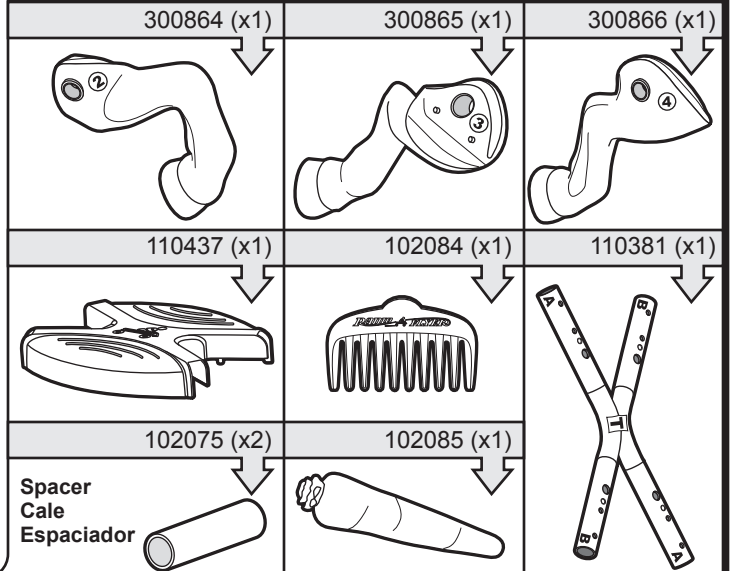

! If you find extra hardware items, please dispose of them and keep them away from small children.
 Si vous avez de éléments an surplus, rangez-les dans un endroit sur, a l'abri des bambins.
 Deshacerse de la ferreteria que le sobre, manteniéndolo fuera del alcance de los niños.

4 CAUTION:

ADULT ASSEMBLY REQUIRED.
This package contains small parts which, before assembly, present a choking hazard to children under the age of three. Care should be taken during unpacking and assembly to ensure that all small parts and plastic bags are accounted for and kept out of the reach of children. All fasteners should be fully tightened.

Please keep instructions for future reference.

ATTENTION:

ASSEMBLAGE REQUIS PAR ADULTE.
Cet emballage contient de petites pièces qui, avant l'assemblage, présentent un danger potentiel de suffocation avec les enfants âgés de moins de trois ans. Prendre les précautions nécessaires au cours du déballage et de l'assemblage afin de garantir que toutes les pièces et sacs en plastique ont été incluses et tenues à l'écart des enfants. Toutes les attaches devraient être bien serrées.

Veuillez garder les instructions comme référence aux besoins.

PRECAUCIÓN:

MONTAJE REQUERIDO POR ADULTOS.
Este paquete contiene pequeñas piezas que, antes del montaje, presentan un peligro potencial de asfixia para niños de menos de tres años de edad. Se debe tener todas las piezas pequeñas y bolsas plásticas fuera del alcance de los niños. Todos los seguros deben ser apretados completamente.

Mantenga por favor las instrucciones para la referencia futura.

5

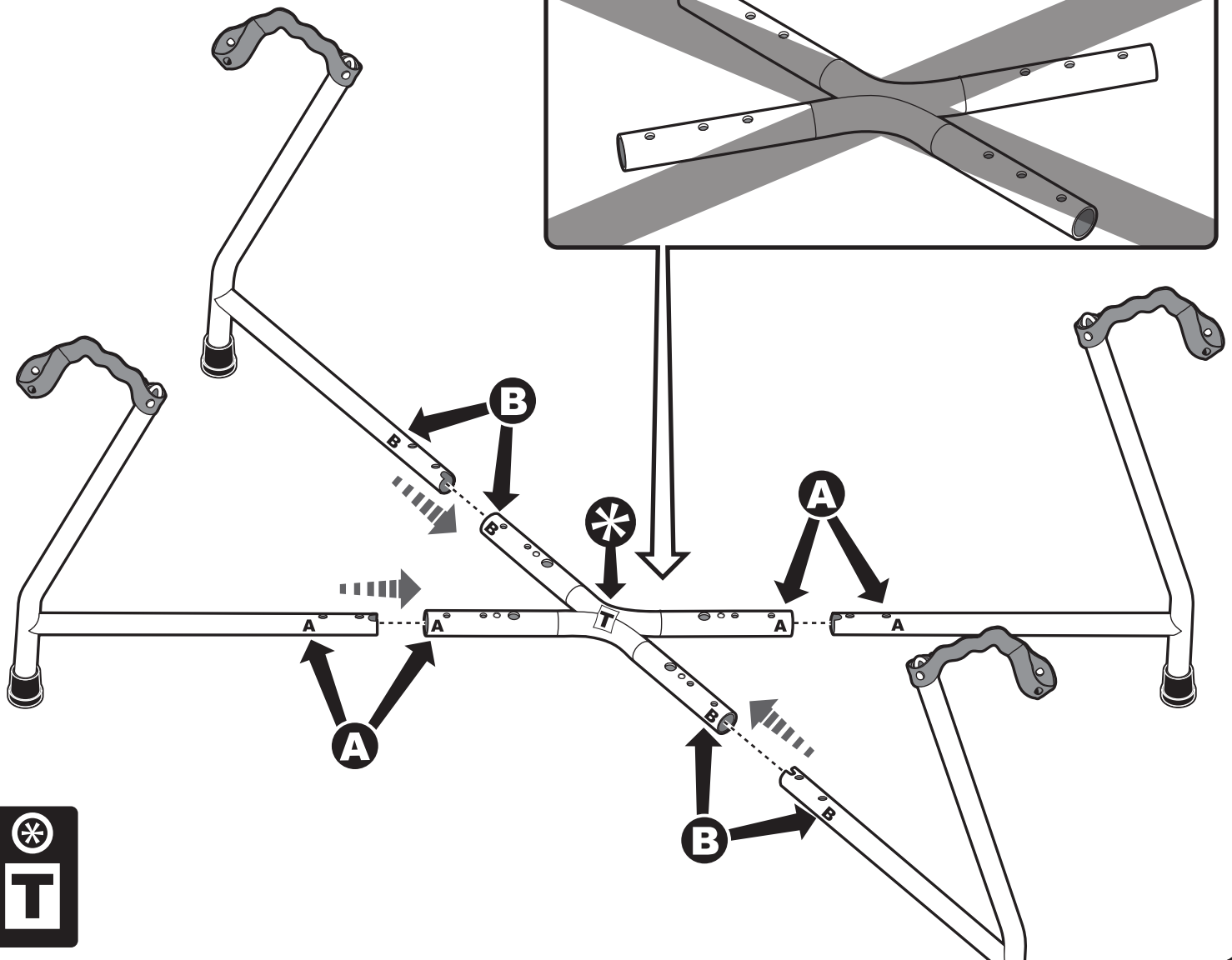
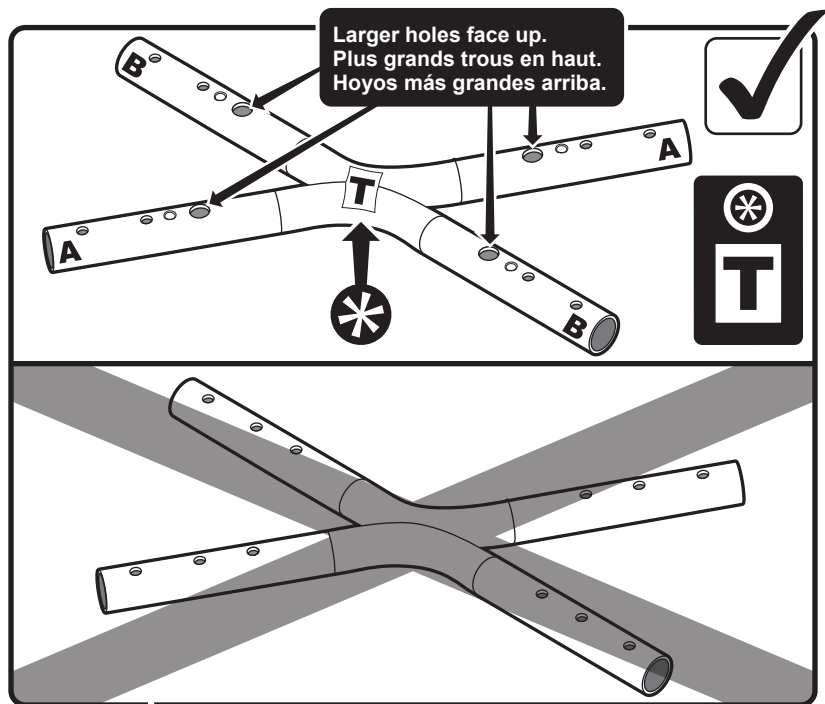

6

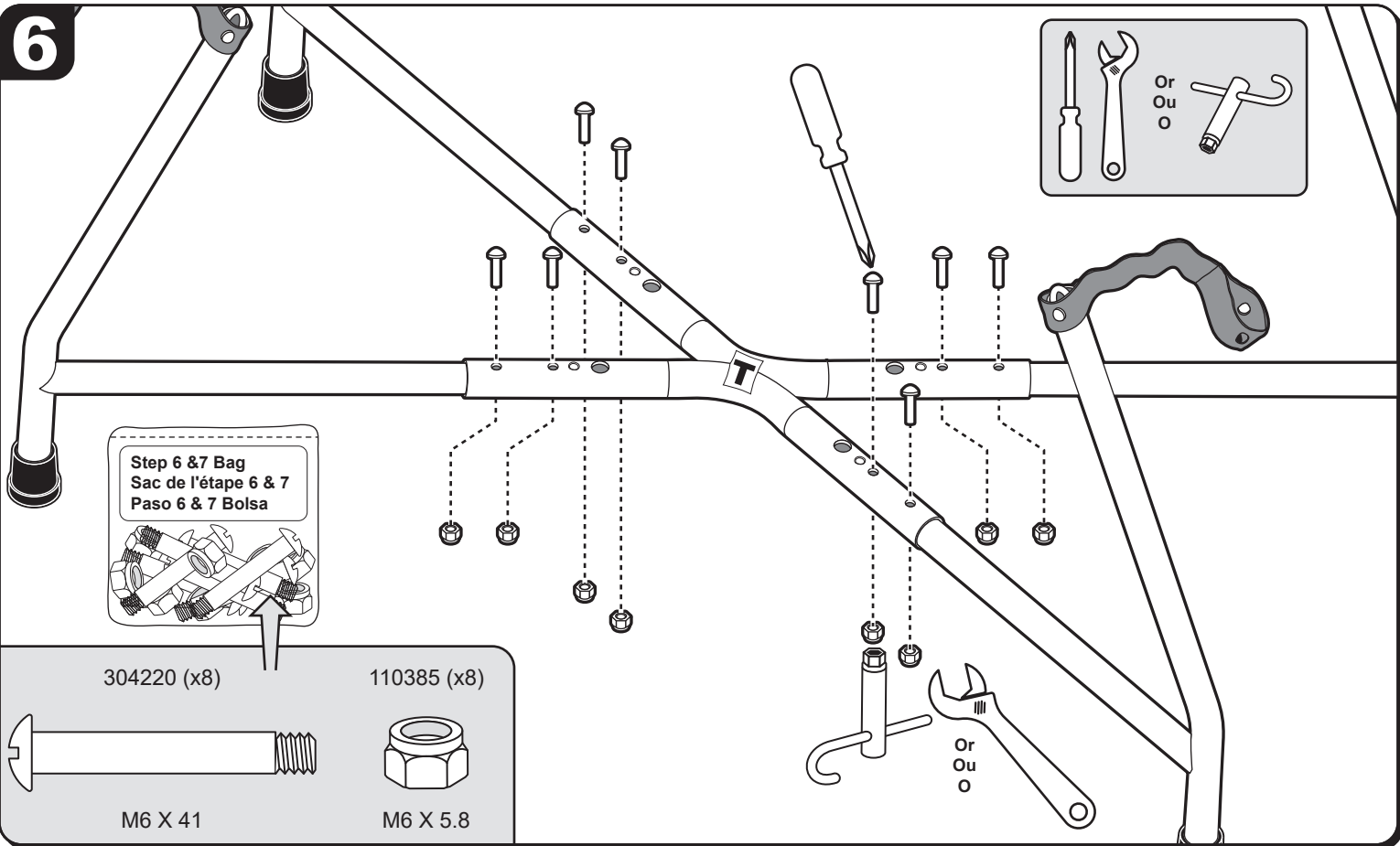

7

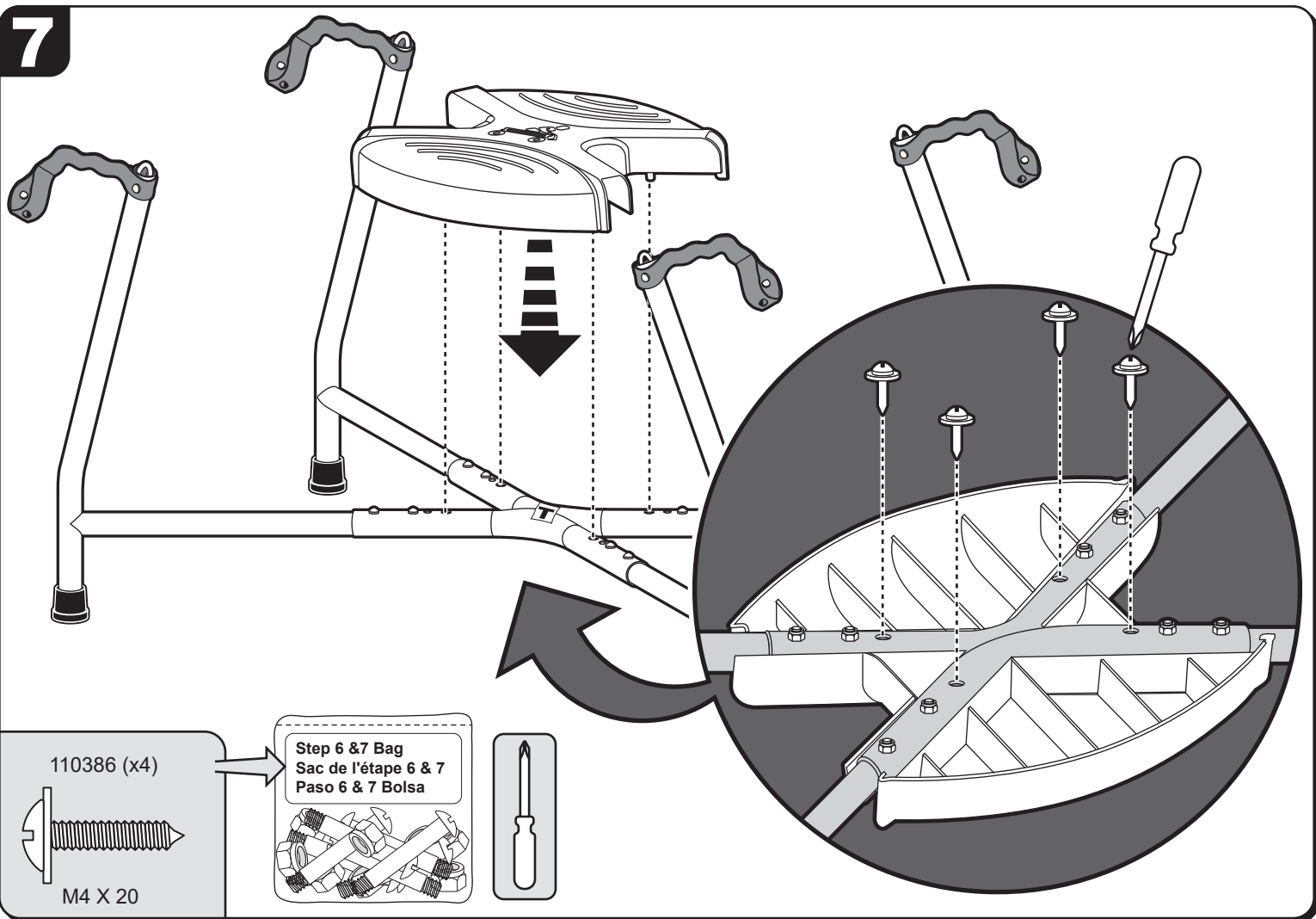

8

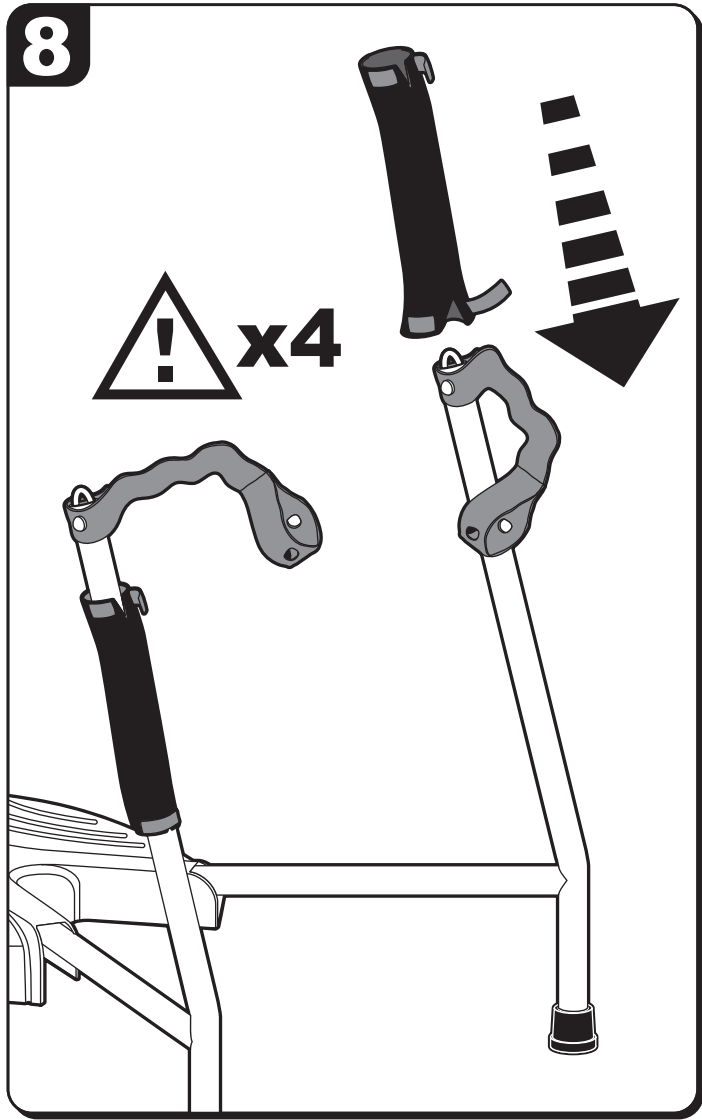

9

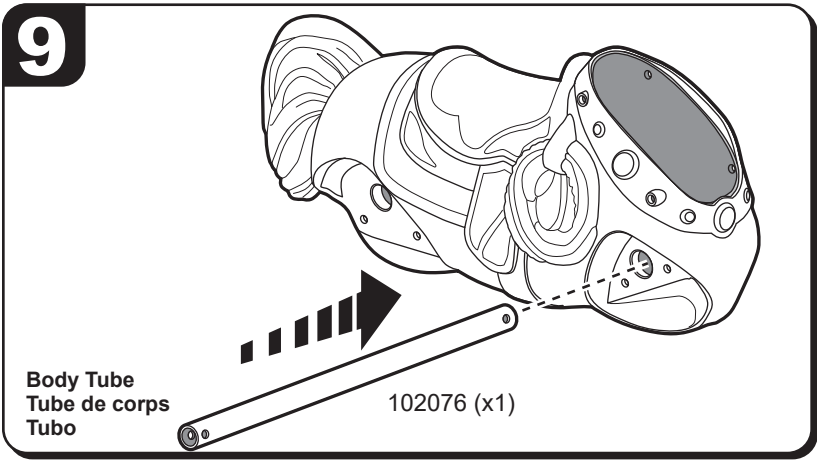

10

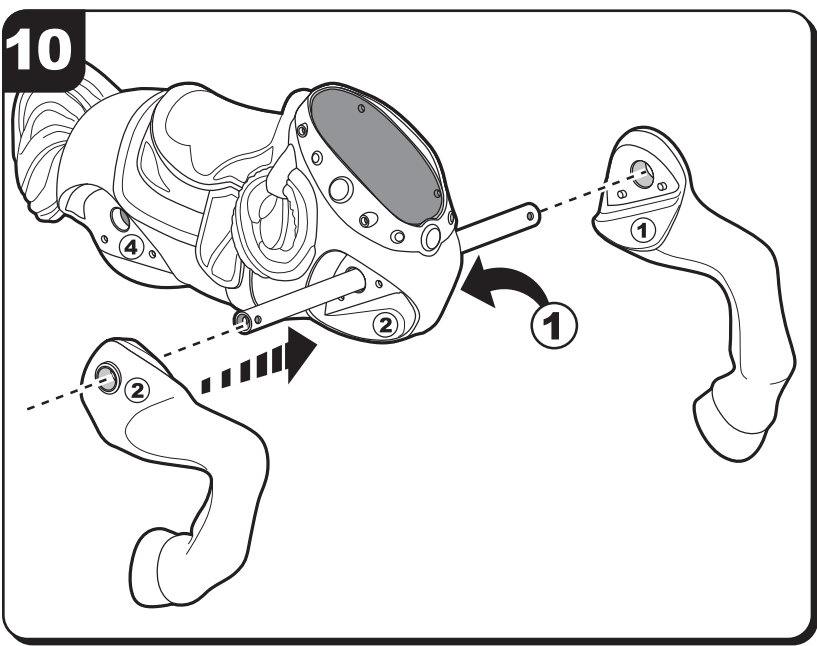

11

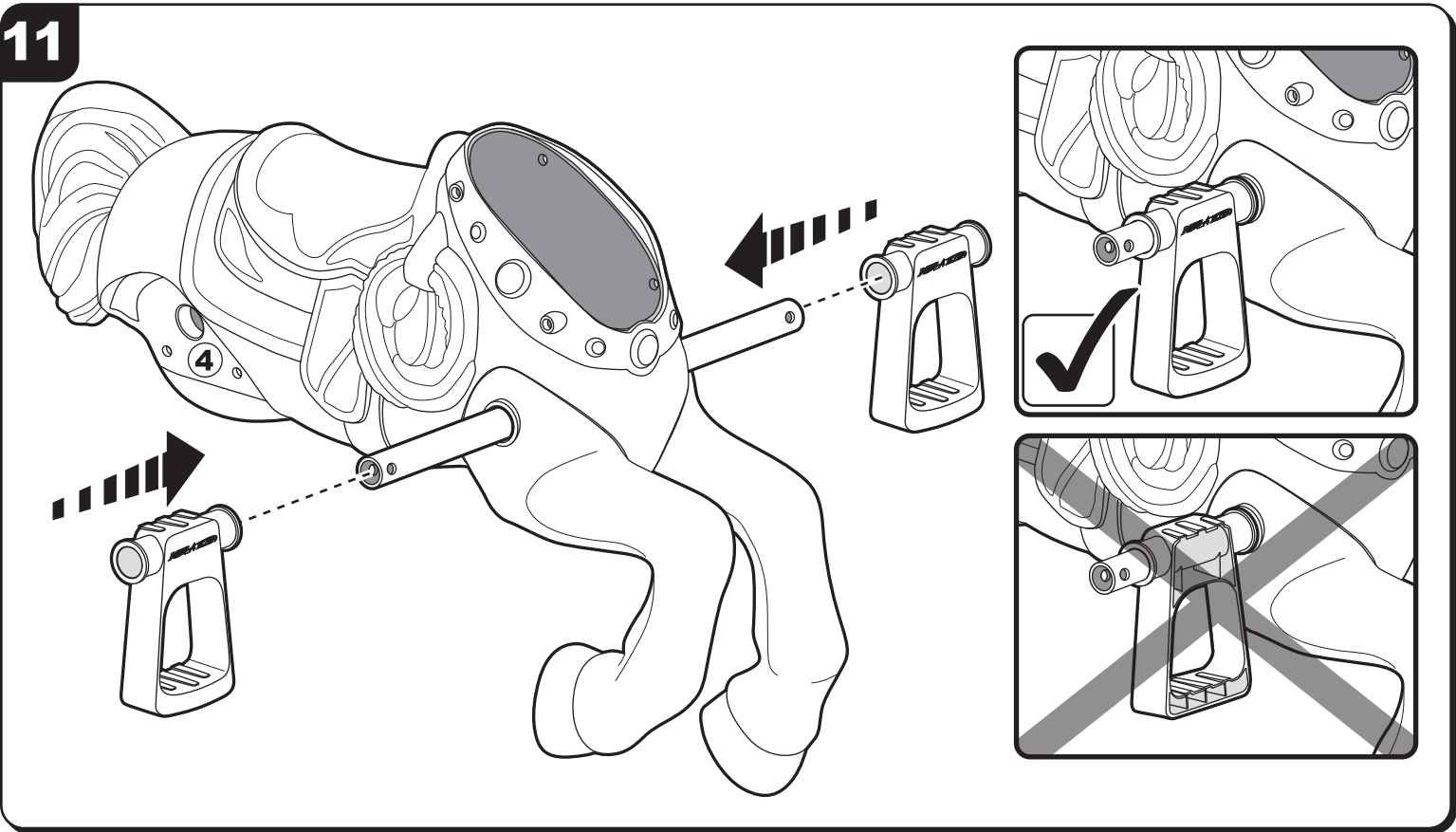

12

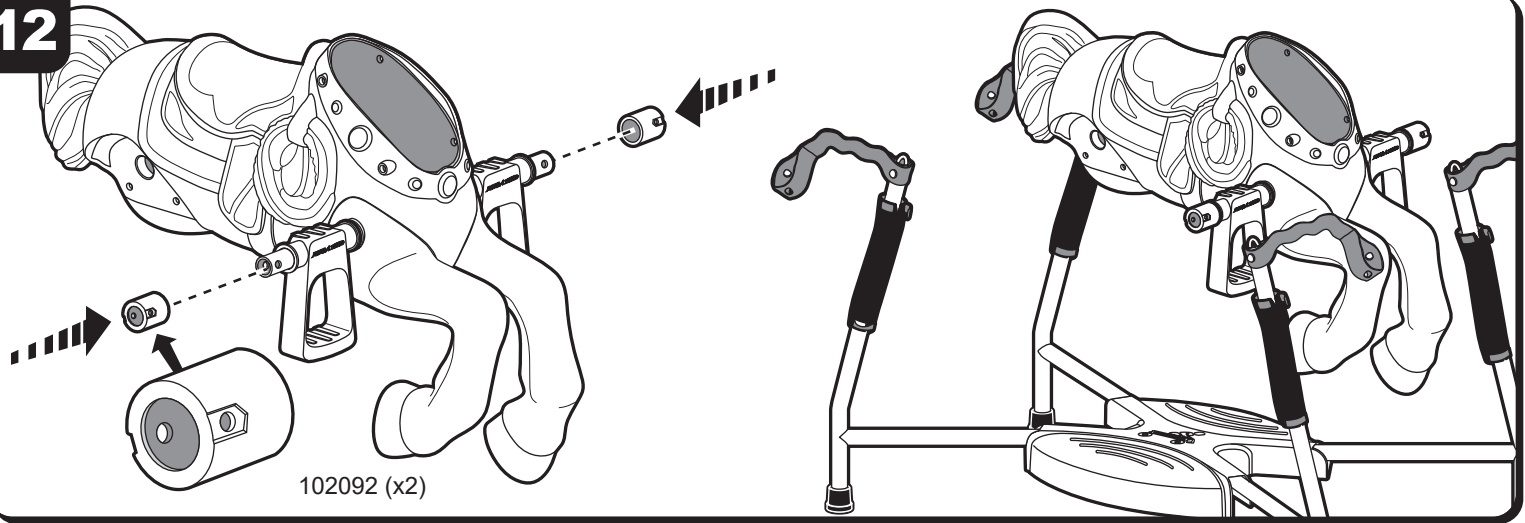

102092 (x2)

13 → a → b → c x2

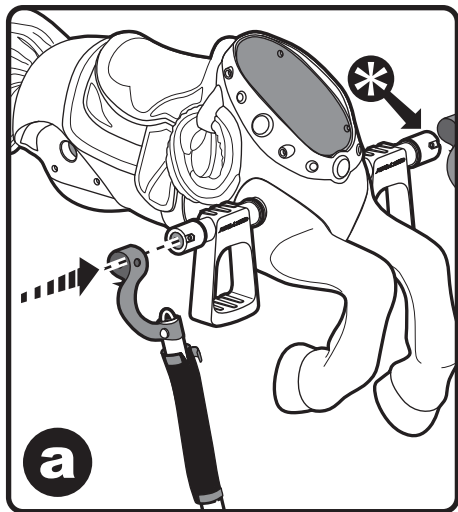

a

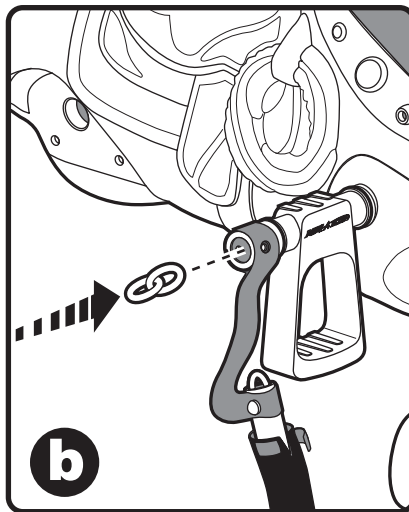

b

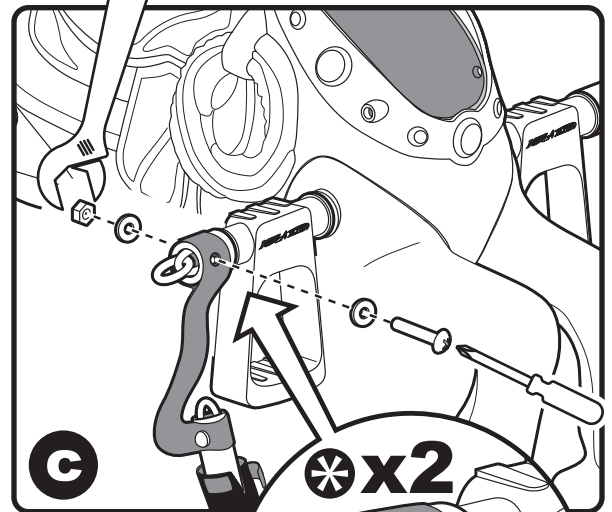

c



102066 (x2)

304220 (x2)

110385 (x2)

100230 (x4)

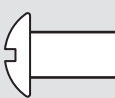

M6 X 41



M6 X 5.8



M6 X 6.4 ID



Step 13&18 Bag
Sac de l'étape 13&18
Paso 13&18 Bolsa

14

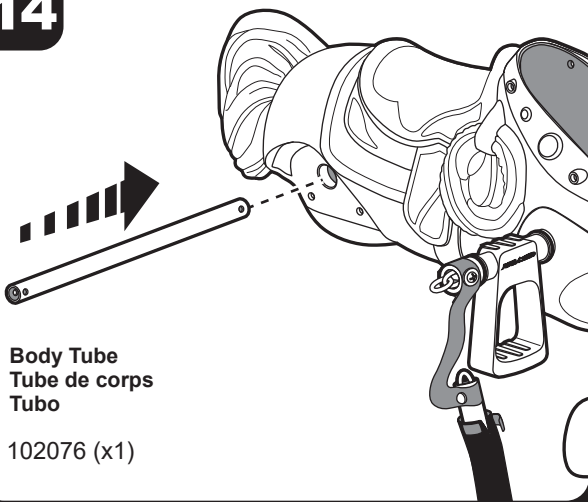

Body Tube
Tube de corps
Tubo

102076 (x1)

15

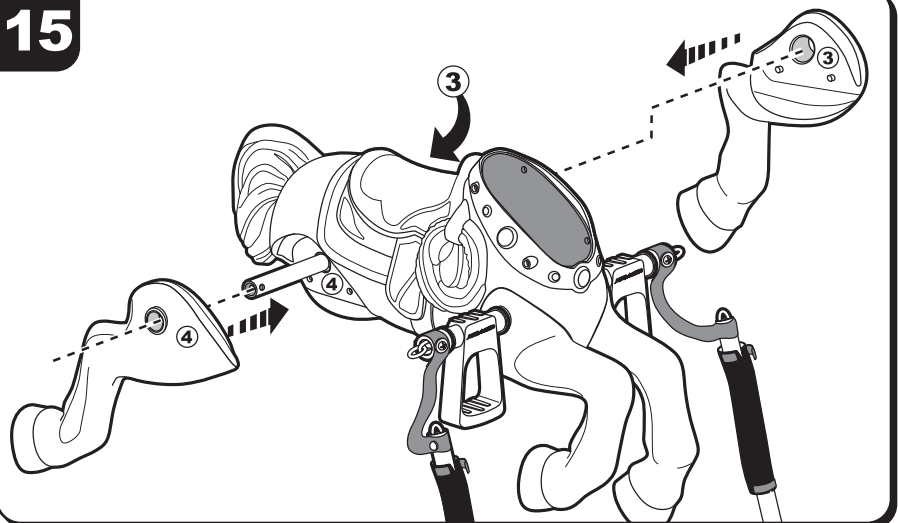

16

Spacer
Cale
Espaciador
102075 (x1)

Spacer
Cale
Espaciador
102075 (x1)

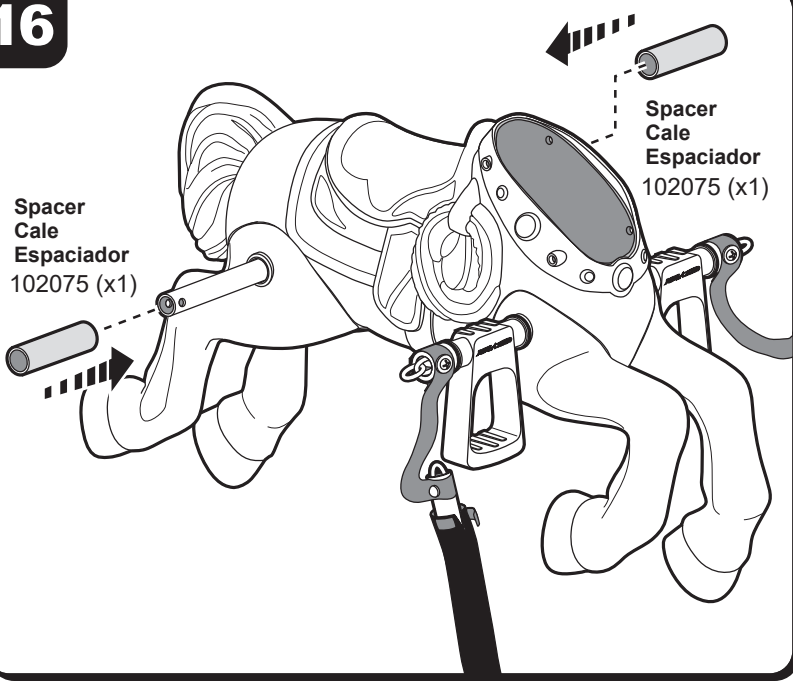

17

102092 (x2)

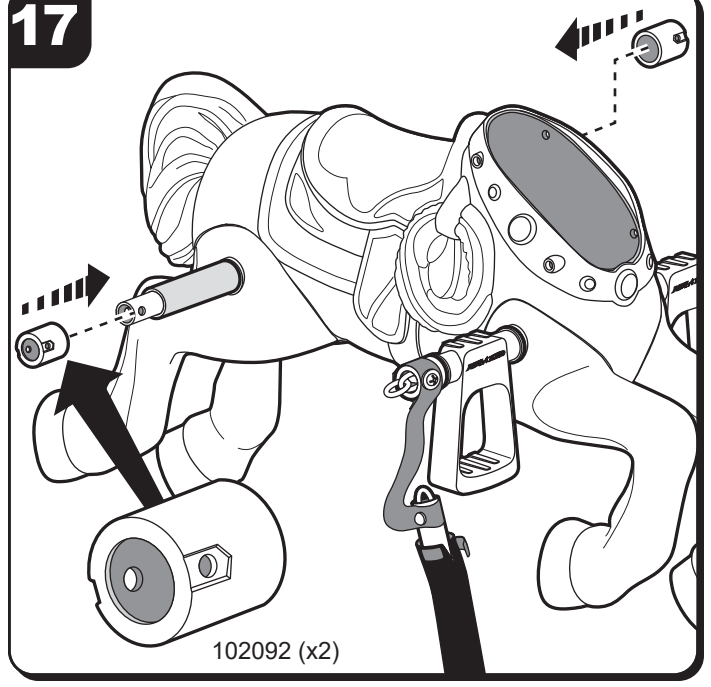

18 → a → b → c x2

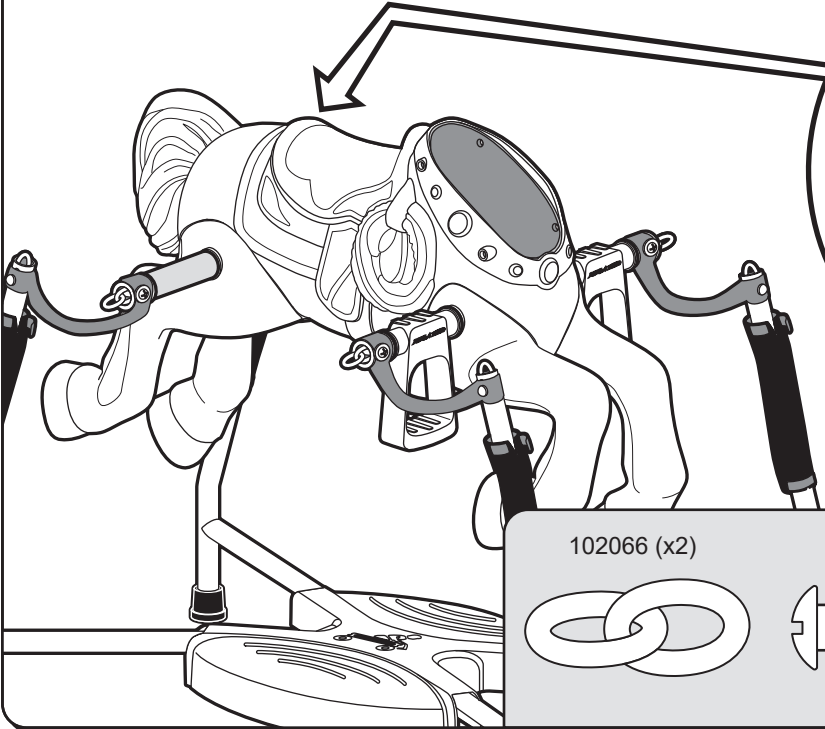
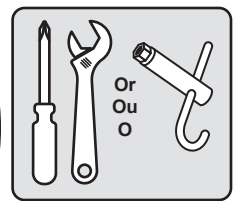
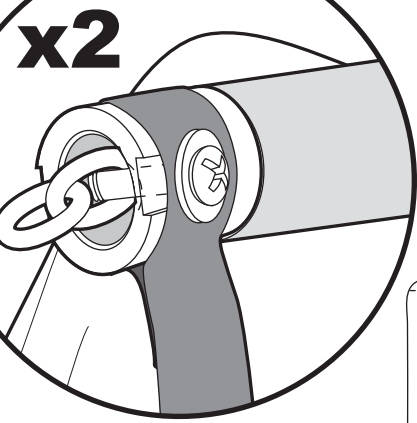
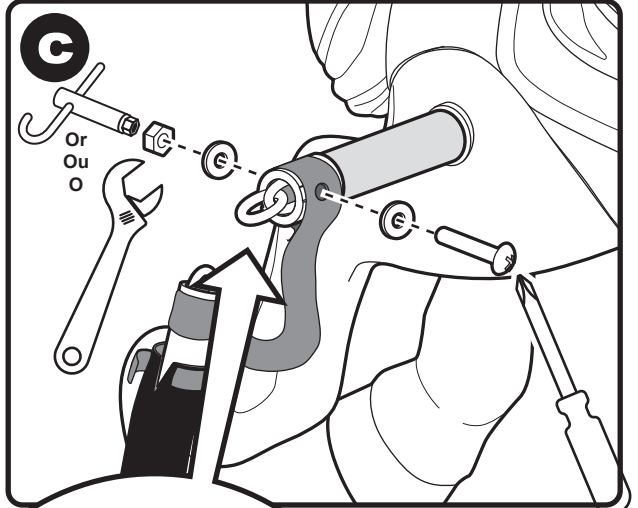
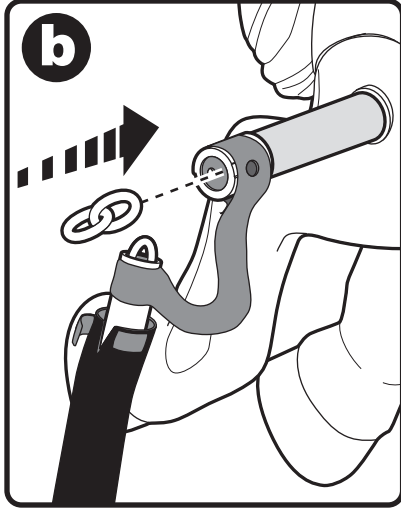
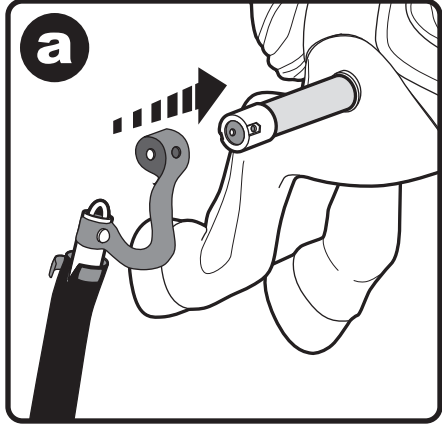

102066 (x2)

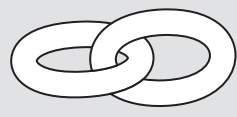

304220 (x2)

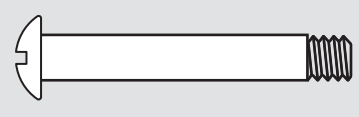

M6 X 41

110385 (x2)



M6 X 5.8

100230 (x4)



M6 X 6.4 ID

19

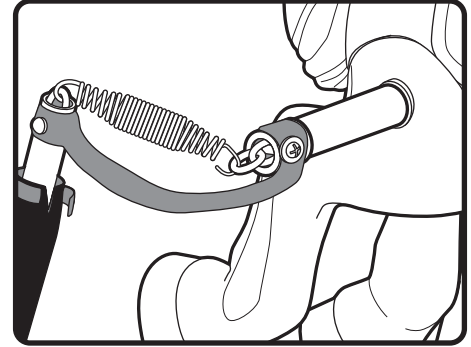
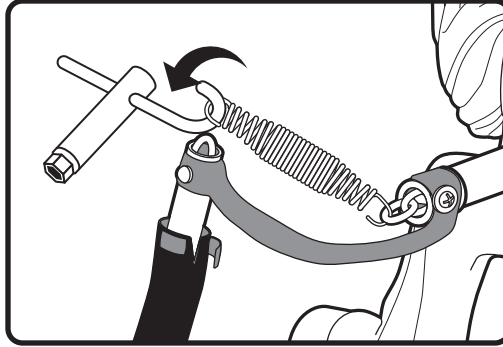
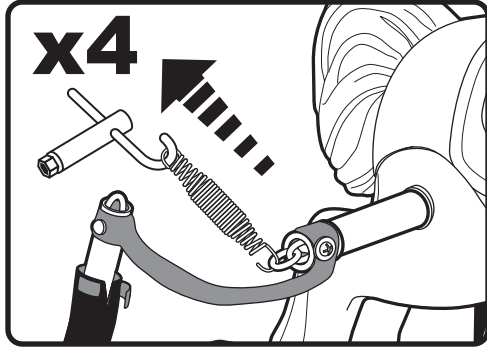
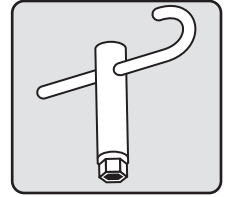
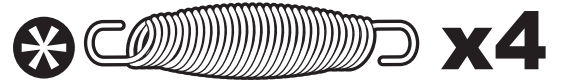
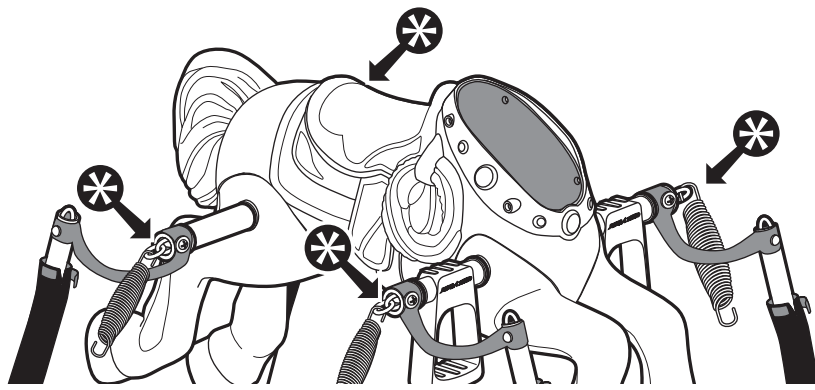

20 → a → b → c → d

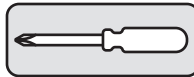

• ON / OFF Switch.
• Interrupteur marche / arrêt.
• Interruptor de encendido/apagado.

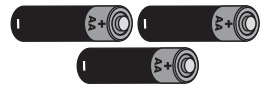

(3 AA Batteries not included.)
(3 Batteries de AA non incluses)
(3 Baterías del AA no incluidas.)

Requires 3 "AA"(Calle LR6 in some countries) batteries. Install new batteries as shown in the polarity diagram (+/-) inside battery compartment. For longer life use only alkaline batteries.

Fonctionne avec 3 piles "AA" (LR6). Mettre de nouvelles piles suivant le diagramme de polarité (+/-) à l'intérieur du compartiment. Pour augmenter la durée de vie des piles alcalines.

Funciona con 3 pilas AA-LR6. Coloque las pilas nuevas siguiendo el diagrama de polaridad (+/-) que se muestra dentro del compartimento para las baterías. Para que la pila dure más, use pilas alcalinas.

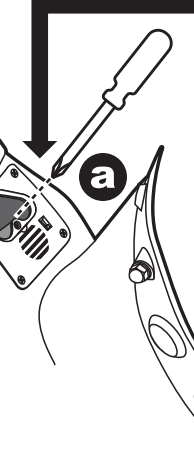
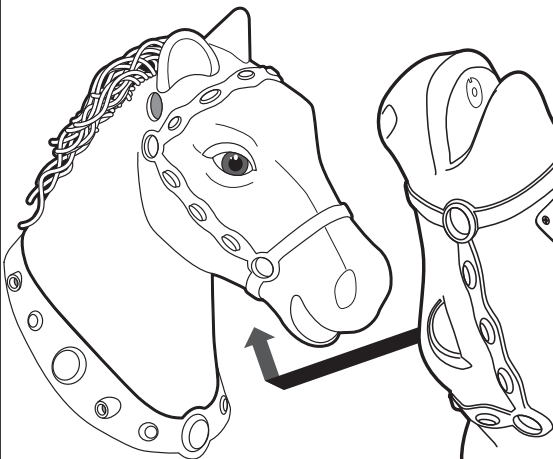

<p>• OFF • Arrêt. • Apagado</p>	<p>• Low volume. • Volume bas. • Volumen bajo.</p>	<p>• High volume. • Volume élevé. • Alto volumen.</p>
---	--	---

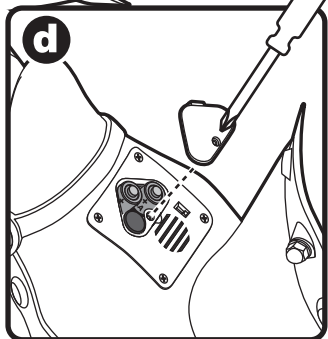
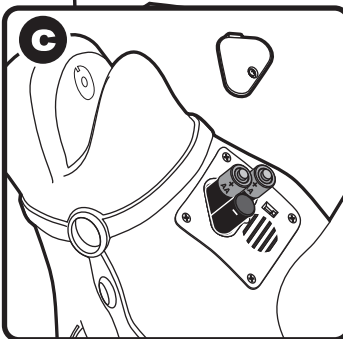
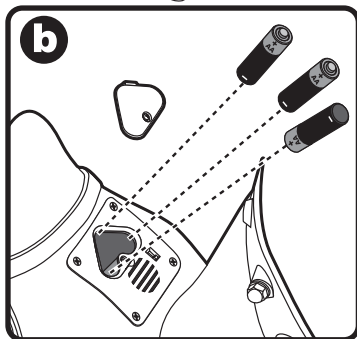

Caution : To Avoid Battery Leakage
DO NOT incinerate used batteries
DO NOT dispose of batteries in fire
DO NOT mix old and new batteries or types of batteries
DO NOT use rechargeable batteries
DO NOT recharge non-rechargeable batteries
DO NOT short-circuit the supply terminals
Different types of batteries should not be mixed.
Only batteries of the same or equivalent type as recommended are to be used.
Exhausted batteries should be removed from the toy.
Dispose of batteries safely.

Attention : pour éviter les fuites
NE PAS incinérer les piles usagées
NE PAS brûler les piles
NE PAS mélanger les piles neuves des piles déjà utilisées ou différents types de piles
NE PAS utiliser des piles rechargeables
NE PAS recharger des piles non-rechargeables
NE PAS court-circuiter les points de livraison
Los tipos diferentes de baterías no se deben mezclar. Sólo baterías del tipo mismo o equivalente como recomendado deberán ser utilizadas.
Las baterías agotadas deberán ser quitadas del juguete. Jetez les piles avec précaution.

Precaución: Para evitar que las pilas se descompongan
NO incinerar las pilas usadas
NO exponga las pilas usadas al fuego
NO mezcle las pilas viejas con las nuevas o tipos diferentes de pilas
NO utilice pilas recargables
NO recargue pilas no recargables
NO haga corto circuito en las terminales
Los tipos diferentes de pilas no deberían pas être mélangés. Seulement les piles de type pareil ou équivalent comme recommandé va être utilisé.
Les piles épuisées devraient être enlevées du jouet. Elimine las pilas de manera segura.

! FCC Statement (U.S. Only)

This device complies with Part 15 of the FCC Rules. Operation is subject to the following two conditions: (1) this device may not cause harmful interference, and (2) this device must accept any interference received, including interference that may cause undesired operation. This equipment has been tested and found to comply with the Limits for a Class B digital device, pursuant to part 15 of the FCC Rules. These limits are designed to provide reasonable protection against harmful interference in a residential installation. This equipment generates, uses and can radiate radio frequency energy, and, if not installed and used in accordance with the instructions, may cause harmful interference to radio communications. However, there is no guarantee that interference will not occur in a particular installation. If this equipment does cause harmful interference to radio or television reception, which can be determined by turning the equipment off and on, the user is encouraged to try to correct the interference by one or more of the following measures:

- Reorient or relocate the receiving antenna.
- Increase the separation between the equipment and the receiver.
- Consult the dealer or an experienced radio/TV technician for help.

CAUTION: Changes or modifications not expressly approved by the party responsible for compliance could void the user's authority to operate the equipment.

CAN ICES-3(B) / NMB-3(B)

21 → **a** → **b**

102087 (x1)

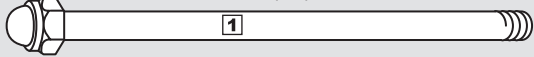

102089 (x2)

102088 (x1)

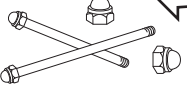
**Step 21 Bag**
Sac de l'étape 21
Paso 21 Bolsas**a****Handle Bar**
Barre
Manubrio**Hand Grip**
Poignées
Manija

102089 (x2)

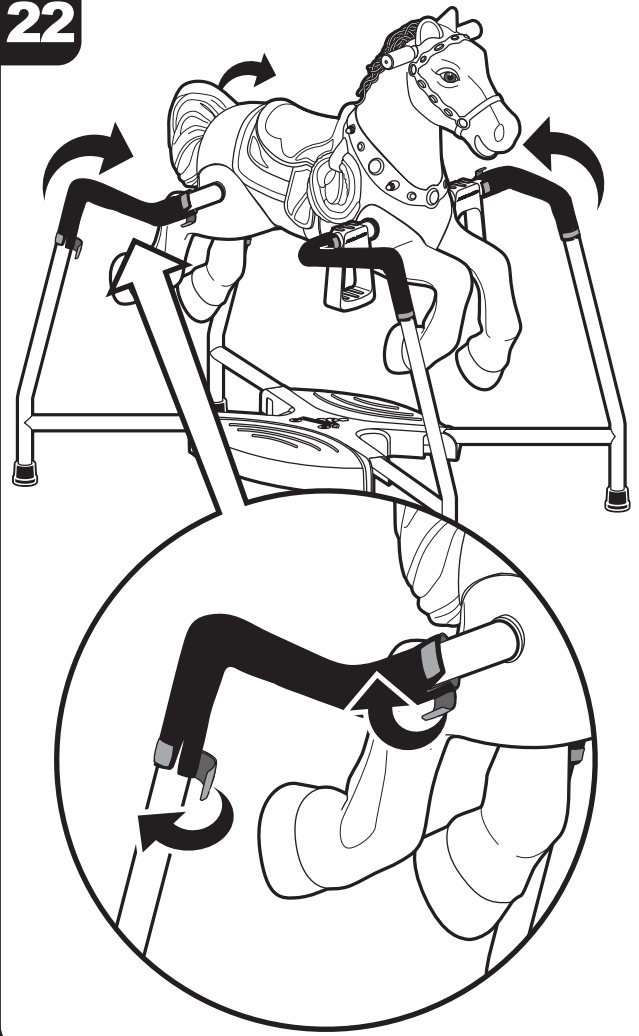
bThe longer **1** rod goes in front.La tige la plus longue **1** doit se trouver à l'avant.Vástago más largo **1** en el frontal.**22****⚠ WARNING:****TO AVOID SERIOUS INJURY:**

- Continuous adult supervision is required.
- Never use near motor vehicles, streets, roadways, alleys, swimming pool areas, hills, steps, sloped driveways, inclines and public highways.
- Only one rider at a time.
- Always wear shoes when using the toy.
- Maximum weight 60.0 lbs. (27.2 kg).
- NEVER allow children in a standing position while on horse.
- Keep floor free from objects that could cause toy to tip.
- Feet should remain in stirrups at all times while riding horse.
- Use on a level surface.
- Store away from sunlight and extreme temperatures.
- Thoroughly check spring horse before each use. All connections must be secure and there should be no loose, defective, worn or missing parts.
- Periodically check all hardware and tighten if needed.
- Check installation and replace batteries if necessary when the sound is distorted.
- Skill is required to avoid falls or collision.

⚠ AVERTISSEMENT:**POUR ÉVITER TOUTE BLESSURE GRAVE:**

- La supervision continu d'un adulte est exigée.
- Ne jamais utilisez près des véhicules à moteur, des rues, des chaussées, des allées, au environs des piscine, des collines, des marches, est des descente en pente des allées, des pentes et des autoroutes publiques.
- Seulement un cavalier à la fois.
- Ne conduisez jamais sans chaussures.
- Charge maximale 27.2 kg (60.0 livres).
- Ne laissez JAMAIS un enfant se mettre debout sur le cheval.
- Assurez-vous qu'aucun objet ne se trouve sur le sol afin d'éviter que le jouet ne se renverse.
- Lors de l'utilisation de ce jouet, l'enfant devra laisser en permanence ses pieds dans les étriers et porter des chaussures.
- L'utilisation de ce jouet doit s'effectuer sur une surface plane.
- Ne stockez pas ce jouet dans un endroit exposé à la lumière du soleil ou à des températures extrêmes.
- Vérifiez entièrement le bon état de marche du cheval à ressort avant chaque utilisation. Tous les points d'attache et pièces doivent être solidement fixés.
- En outre, les pièces ne doivent pas présenter de traces d'usure ou de détérioration ou être solidement fixés.
- Vérifiez périodiquement tous les boulons et resserrez-les si nécessaire.
- Conserve estas instrucciones para referencia futura ya que contienen información importante.
- Certaines compétences de base sont nécessaires afin d'éviter tout risque de chute ou de collision.

⚠ ADVERTENCIA:**PARA EVITAR LESIONES GRAVES:**

- La supervisión adulta continua requerida.
- Nunca uso cerca de automóviles, calles, carreteras, callejones, áreas de piscinas, colinas, pasos, calzadas inclinadas, inclinaciones y carreteras públicas.
- Solamente un jinete a la vez.
- Use siempre los zapatos.
- Peso máximo 27.2 kg (60 lbs.).
- NO permita que los niños se paren sobre el caballo mientras lo utilizan.
- Procure que no haya en el suelo ningún objeto que pueda hacer caer el juguete.
- Cuando se monte el caballo, los pies deberán colocarse siempre en los estribos.
- Colóquese en una superficie plana.
- Guárdese lejos de fuentes de luz y temperaturas extremas.
- Antes de cada uso, revise bien el caballo. Todas las conexiones deben estar bien aseguradas y no debe haber partes sueltas, defectuosas, gastadas o faltantes.
- Revise periódicamente el juguete y ajústelo en caso de ser necesario.
- Revise la instalación y reemplace las pilas si es necesario o si el sonido se distorsiona.
- Se requiere habilidad para evitar las caídas o colisiones.