

RADIO FLYER

Voya™ Stroller Wagon

model/modèle/modelo #3995

- For ages over 6 months.
- Pour les enfants âgés de plus de 6 mois.
- Para niños de más de 6 meses.



Watch Assembly Videos

Scan to find helpful assembly and troubleshooting videos or visit www.radioflyer.com/helpful-hints



Register Your Product

Scan to register this product or visit www.radioflyer.com/register for a chance to win a FREE Radio Flyer product! (One winner selected every month!)

- Thank you for your purchase. If you have any questions or comments, please visit the customer service section of our website: www.radioflyer.com
- Nous vous remercions pour votre achat. Si vous avez des questions ou des commentaires, veuillez consulter la section du service à la clientèle de notre site Web : www.radioflyer.com
- Gracias por su compra. Si tiene alguna pregunta o comentario, visite la sección de atención al cliente de nuestro sitio web: www.radioflyer.com

Or phone / ou appeler le / o llame al 1-800-621-7613

- Available weekdays 8:00 a.m. to 5:00 p.m. CST.
- Disponible en semaine de 8 h à 17 h HNC.
- Disponible en días hábiles, de 8:00 a. m. a 5:00 p. m. CST.
- Please keep this sheet for future reference.
- Veuillez conserver cette feuille pour vous y référer ultérieurement.
- Conserve esta hoja por si la necesita en el futuro.

Radio Flyer Inc. / 6515 West Grand Ave. / Chicago, IL 60707
phone: 1-800-621-7613



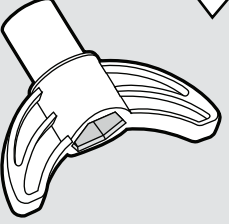

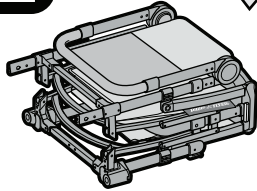
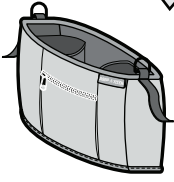
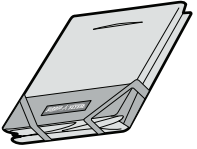
The Original Little Red Wagon™ - Since 1917

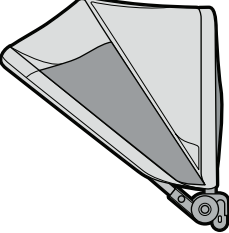
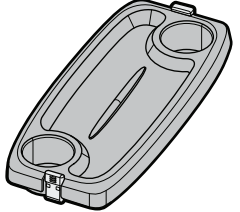

1	Required: Nécessaire: Requeridas:		Included: Inclus: Incluido:	306867 (x1) 

2	313466 (x1) 	313468 (x1) 	313244 (x1) 
----------	---	--	--

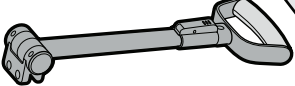
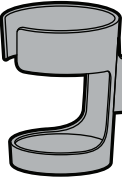
313371 (x2) 	313240 (x1) 
---	--

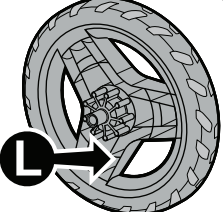
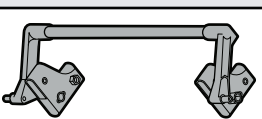
313232 (x1) 

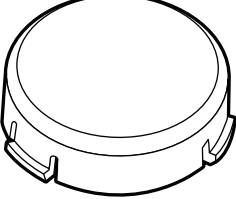
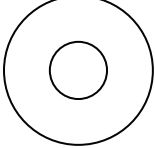
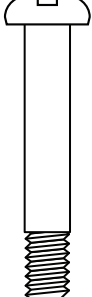
313363 (x1) 	313352 (x1) 	313319 (x1) 	313233 (x2) 	313364 (x1) 	313370 (x1) 
		313346 (x1) 			

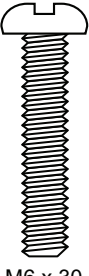
3	Hardware Bag 313411 (x1): Sac matériel 313411 (x1): Bolsa de tornillos 313411 (x1):	313415 (x2) 	306865 (x2) 	312331 (x2) 	306864 (x2) 	313318 (x2) 
			M8	M6 x 38	M8	M6 x 30

! If you find extra hardware items, please dispose of them and keep them away from small children.
Si vous avez des éléments en surplus, rangez-les dans un endroit sur, à l'abri des bambins.
■ Deshacerse de la ferretería que le sobre, manteniéndolo fuera del alcance de los niños.

4 ⚠️ WARNING:

ADULT ASSEMBLY REQUIRED.

Choking hazard to children under the age of 3 years – contains small parts prior to assembly. All fasteners should be fully tightened.

Please keep instructions for future reference.

⚠️ AVERTISSEMENT:

ASSEMBLAGE REQUIS PAR ADULTE.

Risque d'étouffement pour les enfants de moins de trois ans – Contient des pièces de petite taille avant assemblage. Toutes les attaches devraient être bien serrées.

Veuillez garder les instructions comme référence aux besoins.

⚠️ ADVERTENCIA:

MONTAJE REQUERIDO POR ADULTOS.

Peligro de asfixia a niños menores de 3 años - contiene piezas pequeñas antes del montaje. Todos los seguros deben ser apretado s completamente.

Mantenga por favor las instrucciones para la referencia futura.

5

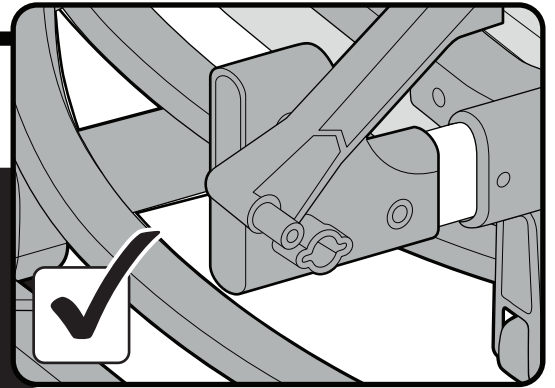
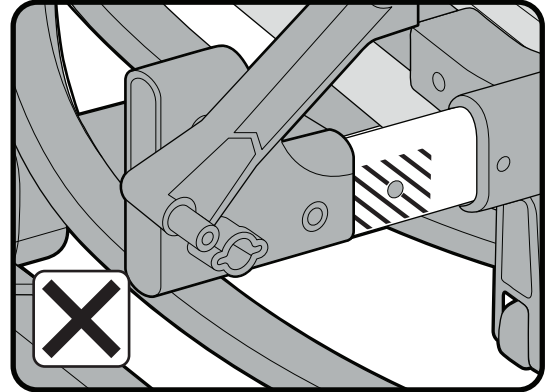
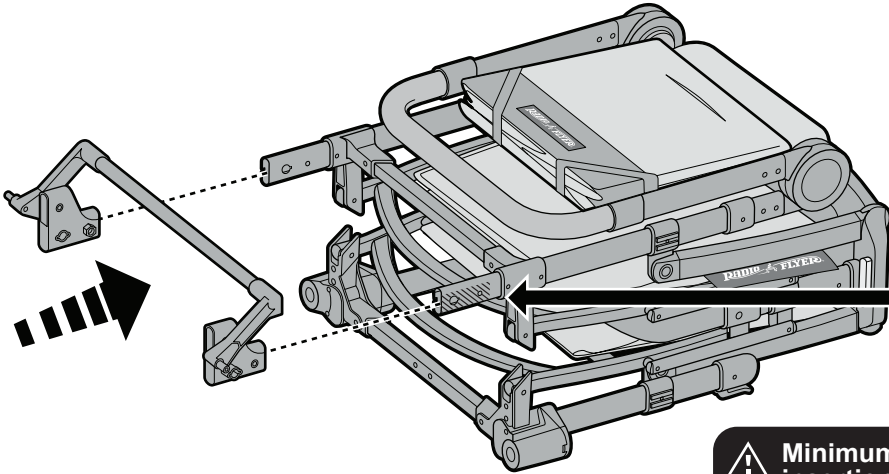

- ⚠️ Minimum insertion.
- ⚠️ Insertion minimale.
- ⚠️ Inserción mínima.

6

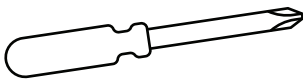

- Tighten
- Serrer
- Apriete

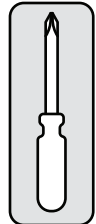

313318 (x2)

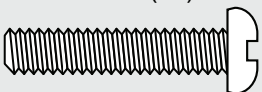

M6 x 30

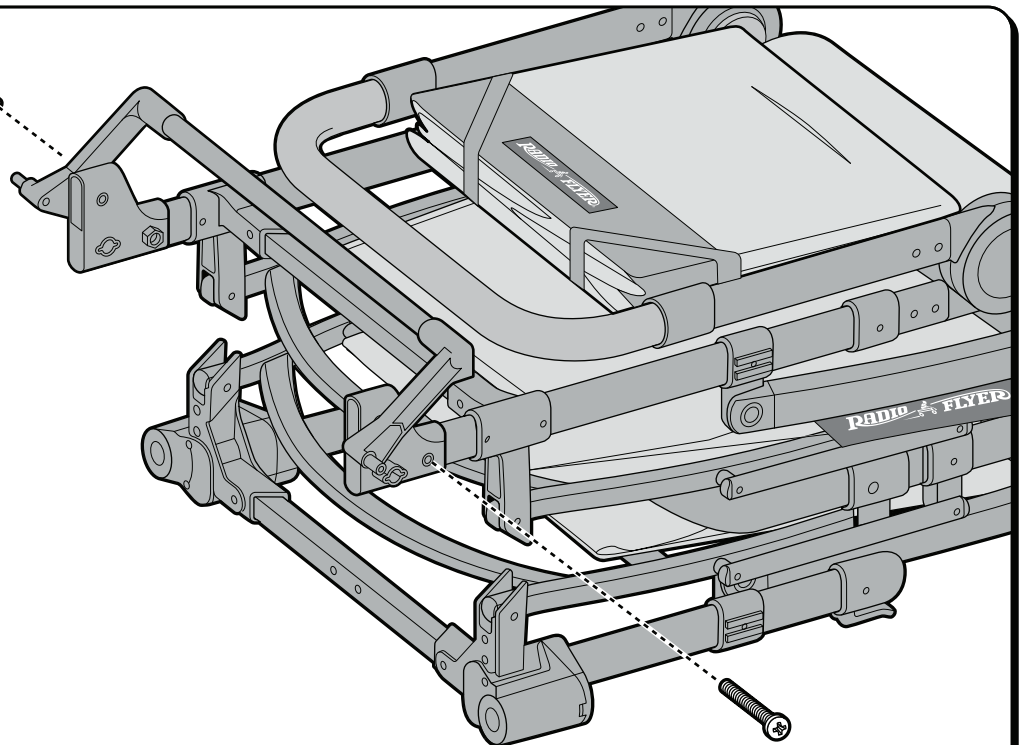

7

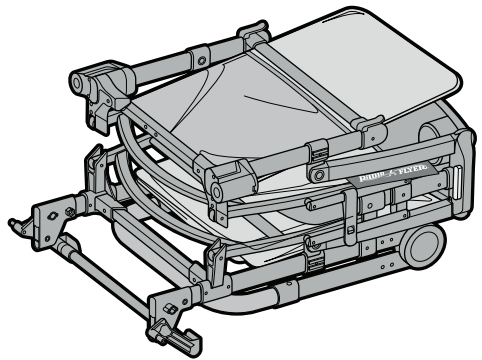
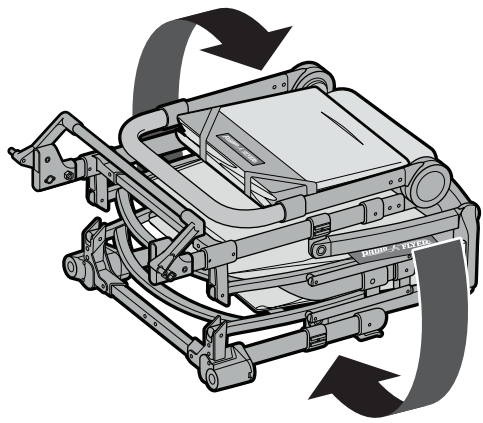

8

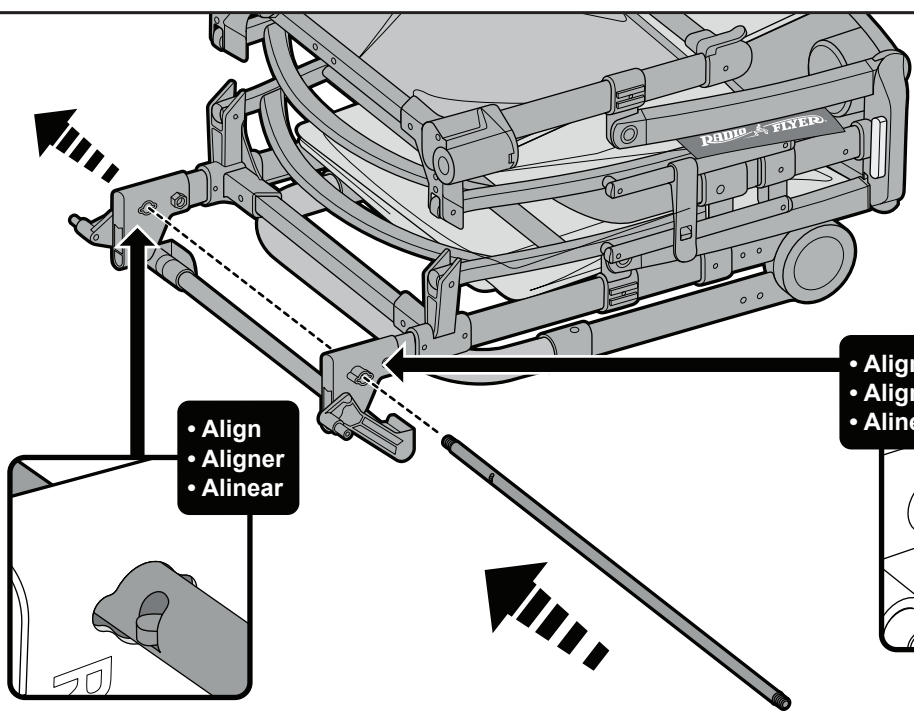

- Align
- Aligner
- Alinear

- Align
- Aligner
- Alinear

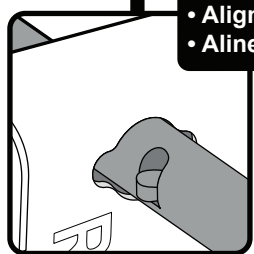
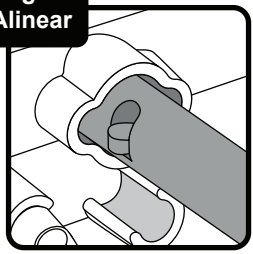

9

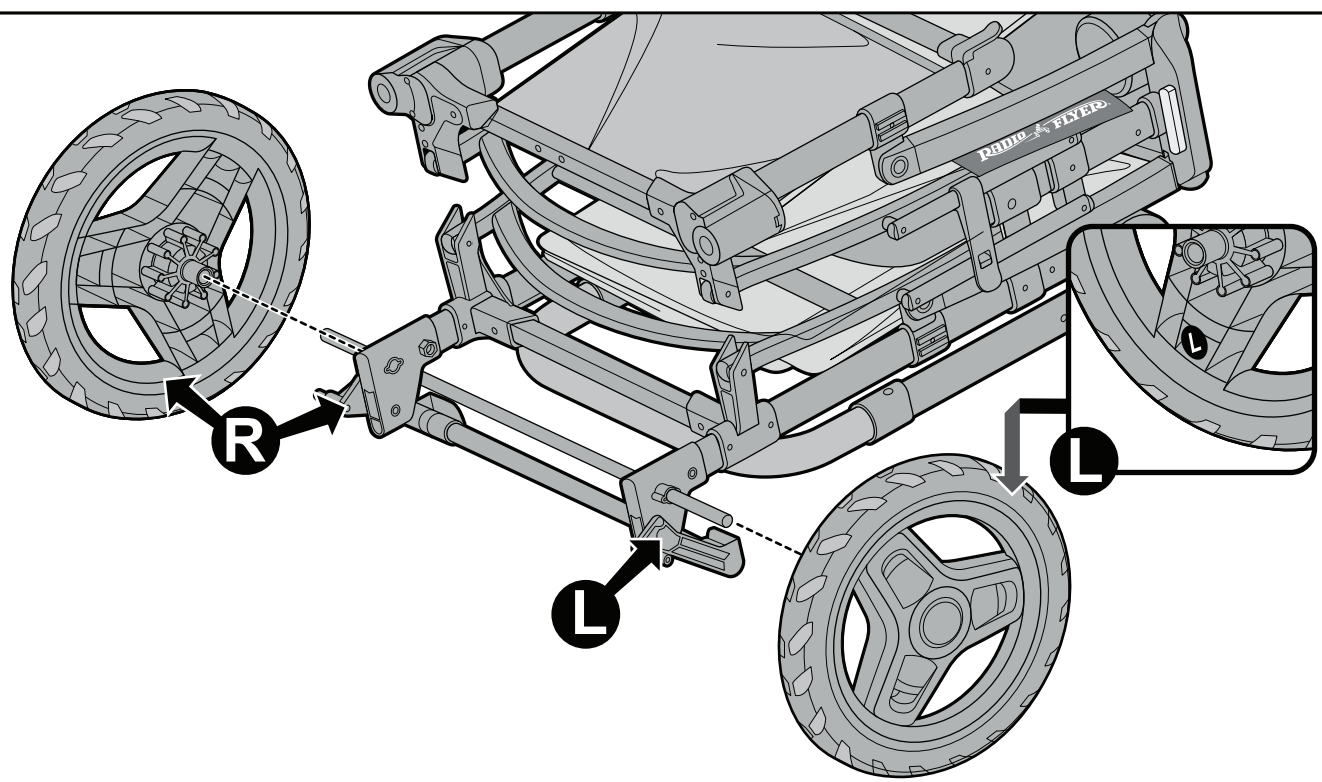

10

- Tighten
- Serrer
- Apriete

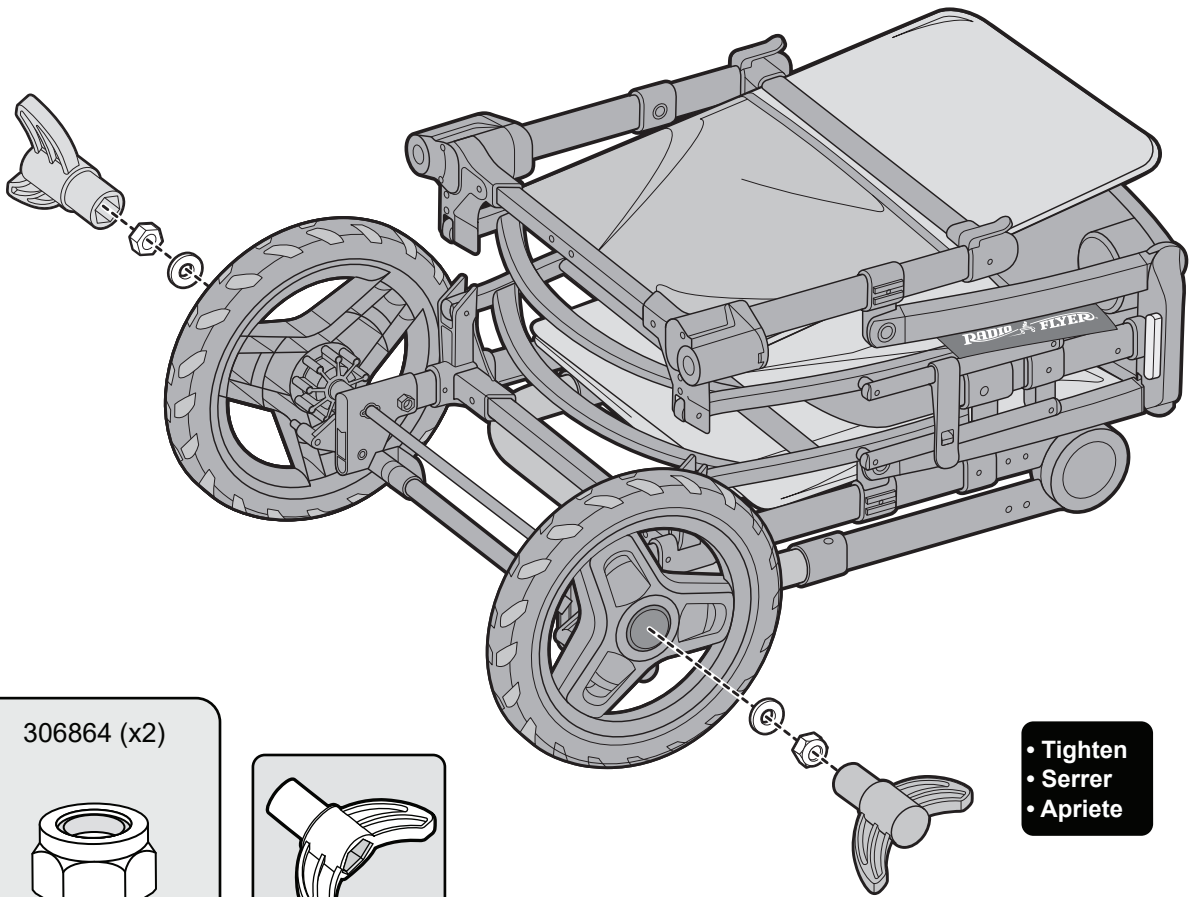

306865 (x2)

306864 (x2)



M8

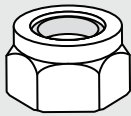

M8

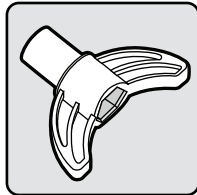

- Tighten
- Serrer
- Apriete

11

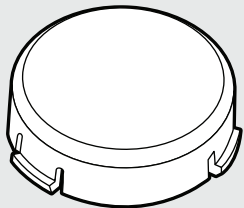
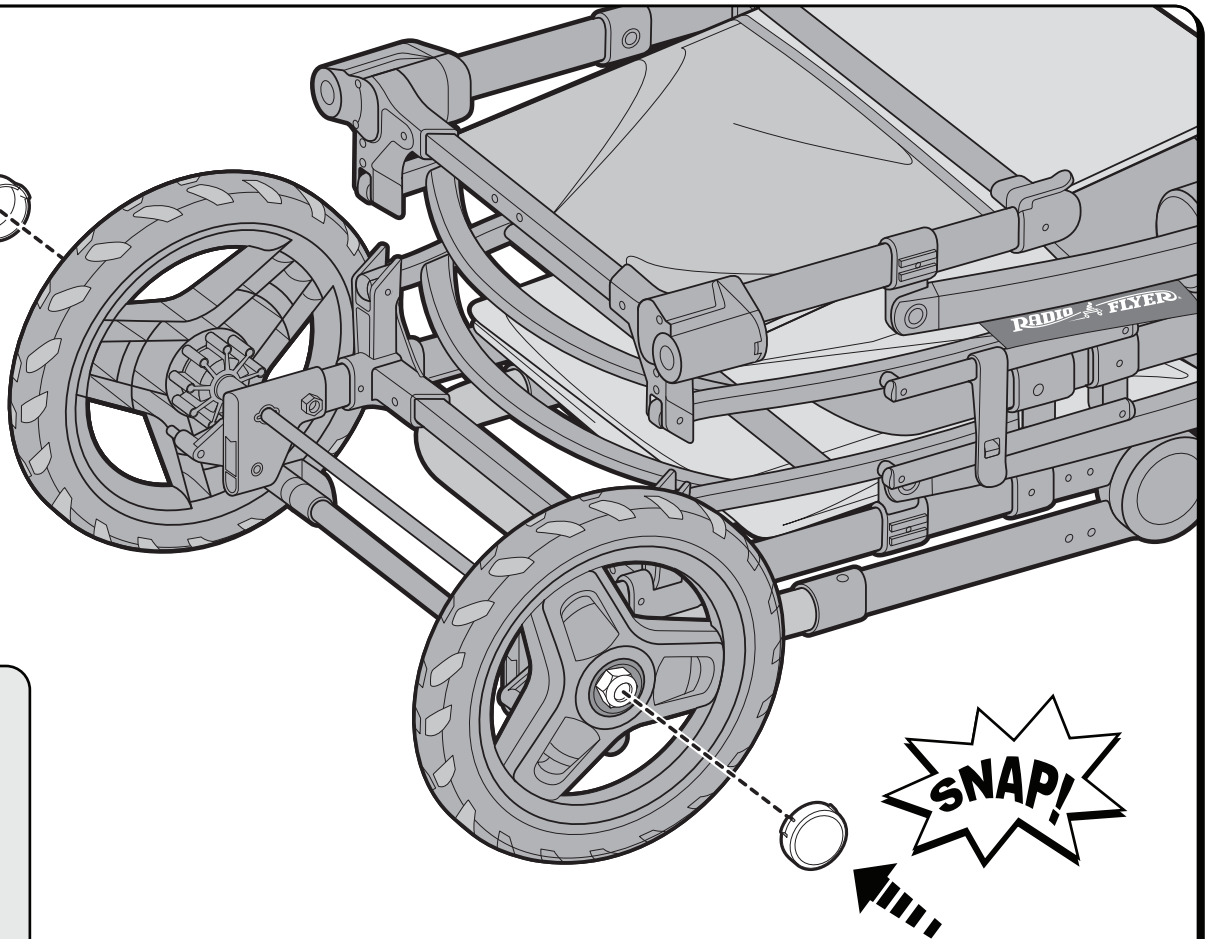
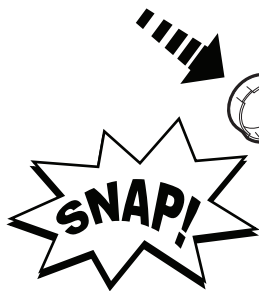

313415 (x2)

12

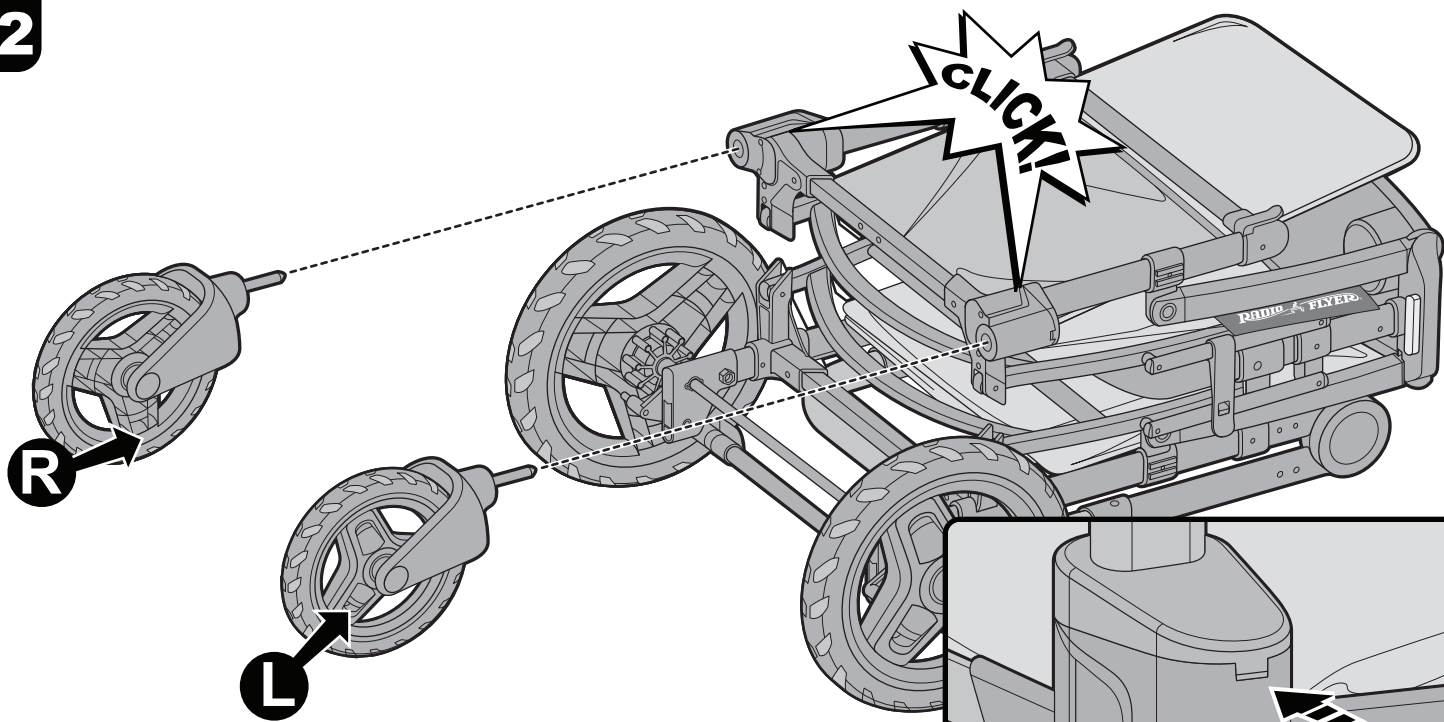

- To remove front wheels, depress tab with screwdriver.
- Pour retirer les roues avant, appuyez sur la languette avec un tournevis.
- Para quitar las ruedas delanteras, presione la lengüeta con un destornillador.

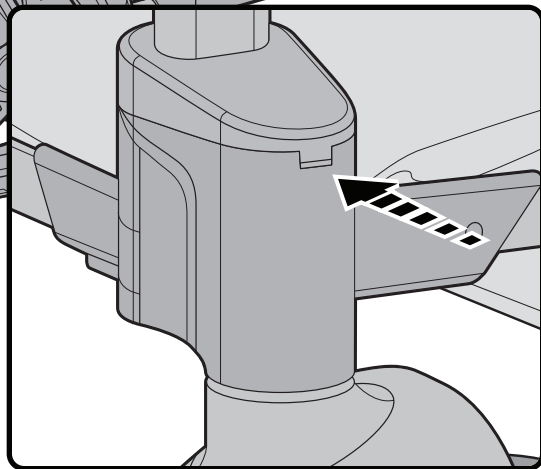

13

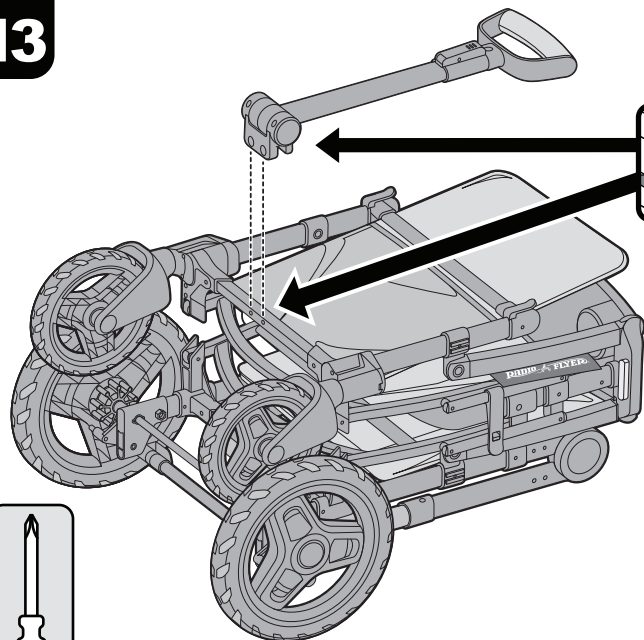

- Align holes.
- Aligner les trous.
- Alinear los agujeros.

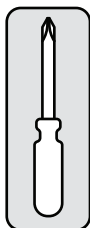

312331 (x2)

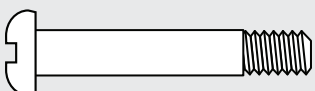

M6 x 38

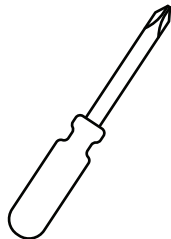

- Tighten
- Serrer
- Apriete

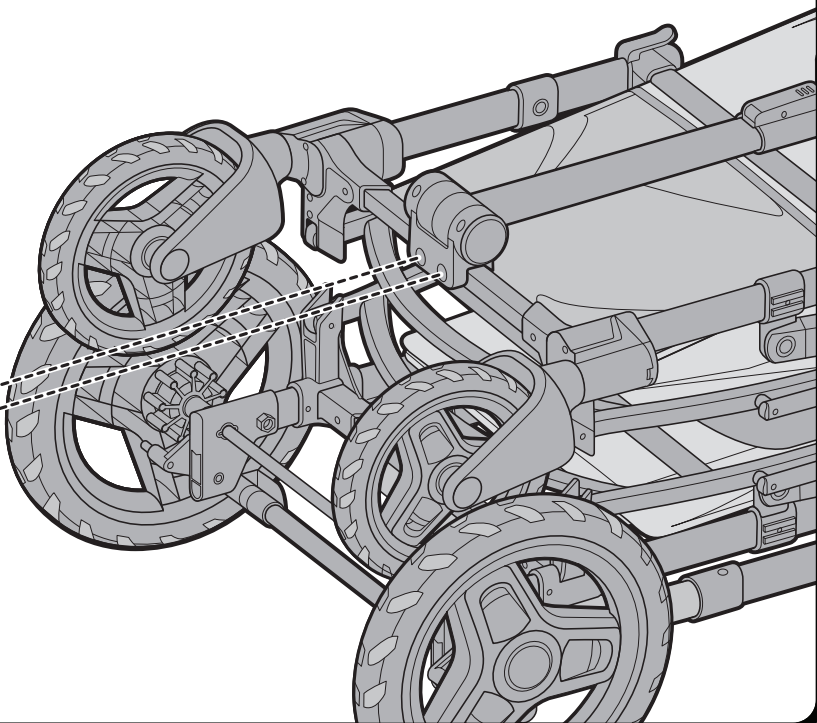

14

- To unfold:
- Se dérouler:
- A desarmarse:

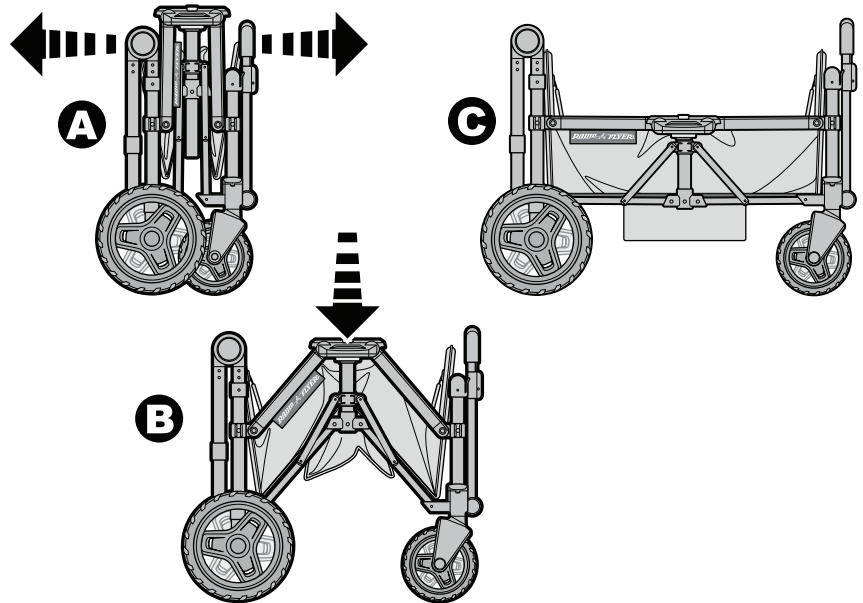
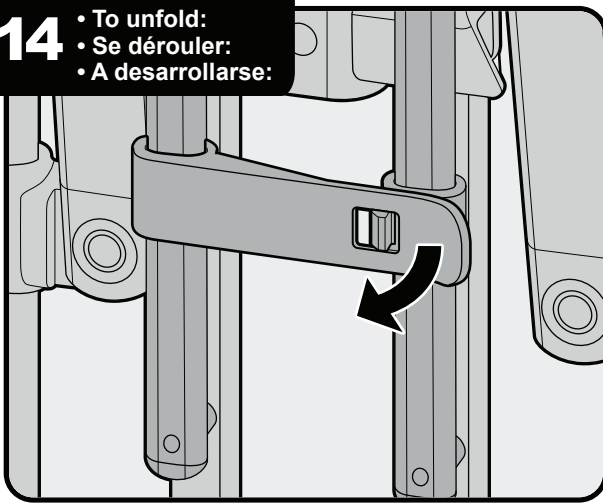

- Pull tab back to unlock.
- Tirez la languette vers l'arrière pour déverrouiller.
- Tire de la pestaña hacia atrás para desbloquear.

15

- Unfold storage bag:
- Déplier le sac de rangement:
- Desplegar bolsa de almacenamiento:

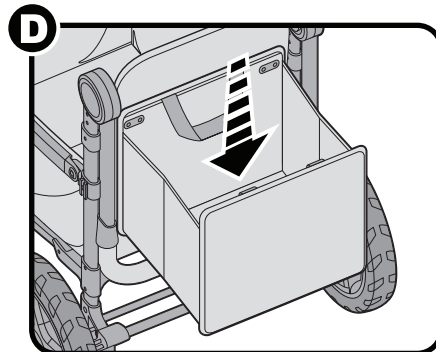
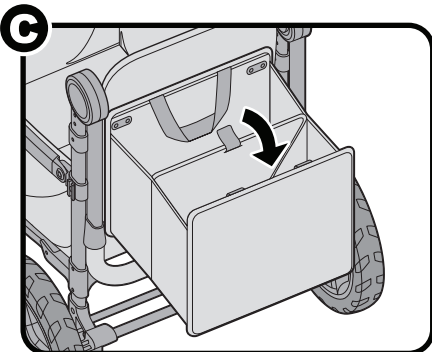
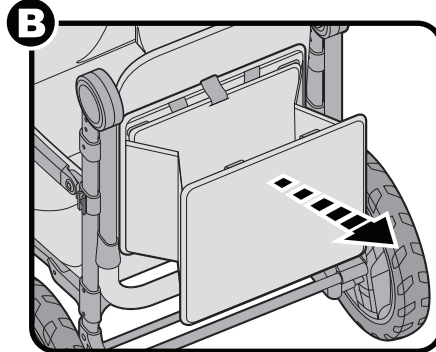
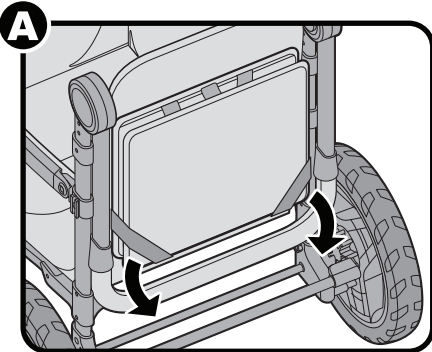

- Pull up to remove bag
- Tirez vers le haut pour retirer le sac.
- Tire hacia arriba para quitar la bolsa.

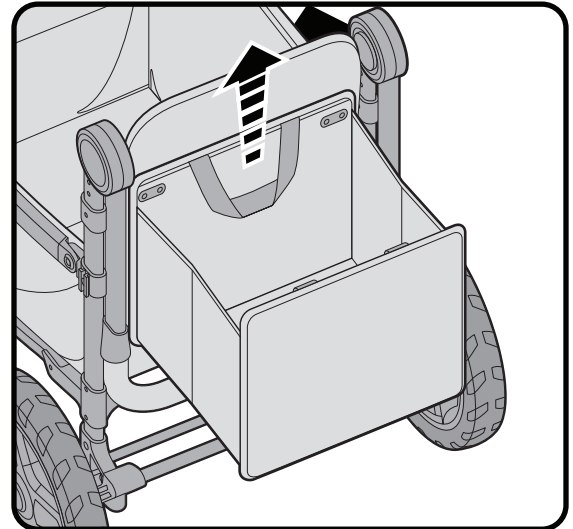

⚠ Maximum weight the rear bag is designed to carry is 20.0 lbs (9.0 kg).

⚠ Le poids maximum le sac arrière est conçu à porter est 9,0 kg.

⚠ Cantidad máxima de peso para la bolsa trasera es de 9,0 kg.

- Snap bag over rear crossbar during use.
- Enclenchez le sac sur la barre transversale arrière pendant l'utilisation.
- Coloque la bolsa sobre el travesaño trasero durante el uso.

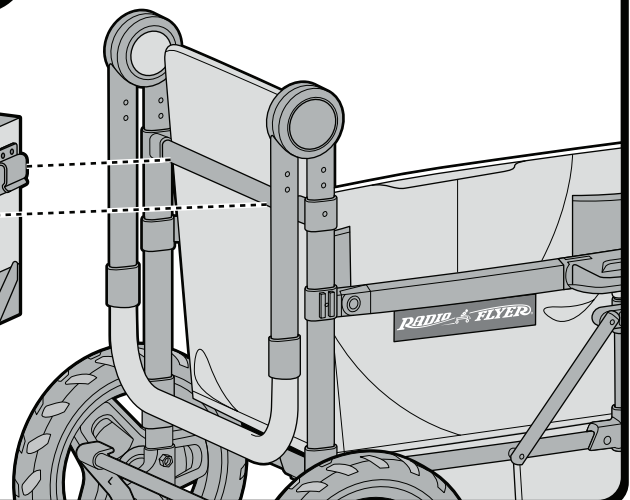
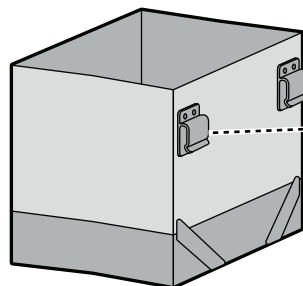

16

- Cupholder use:
- Utilisation du porte-gobelet:
- Uso de portavasos:

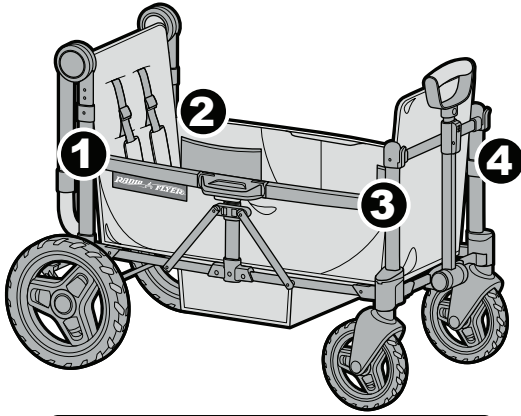

- Four mounting locations.
- Quatre emplacements de montage.
- Cuatro ubicaciones de montaje.

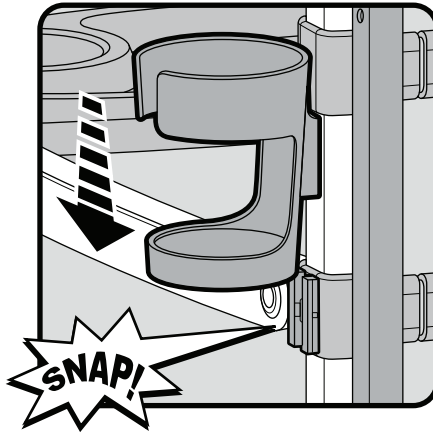

- Push down to attach.
- Poussez vers le bas pour attacher.
- Empuje hacia abajo para adjuntar.

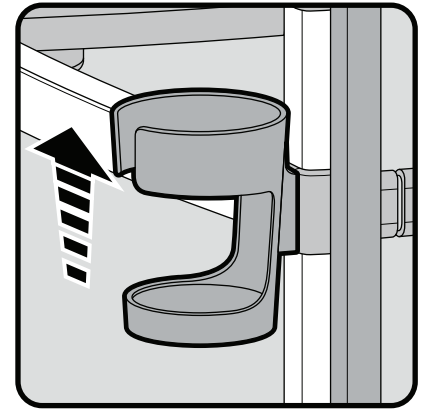

- Pull up to detach.
- Tirez pour détacher.
- Tire hacia arriba para separar.

17

- Parent caddy use:
- Utilisation du cadet des parents:
- Uso de carrito de padres:

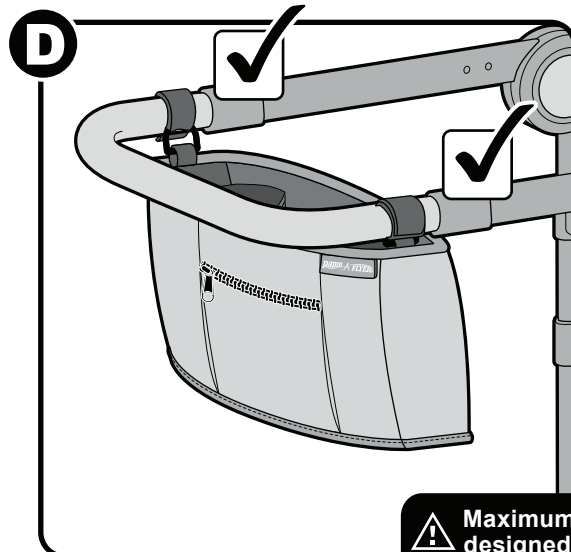
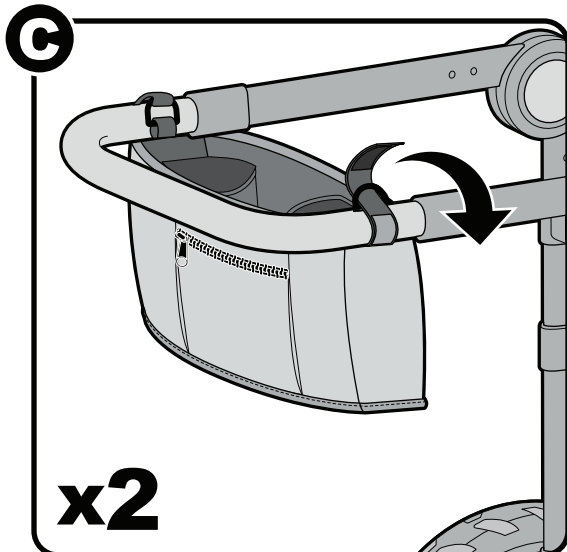
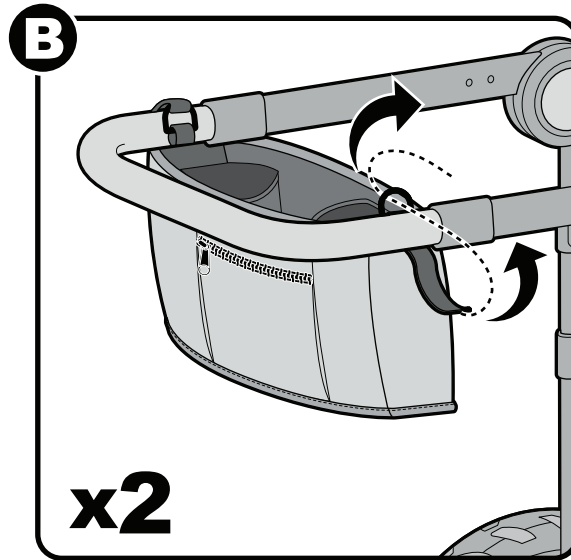
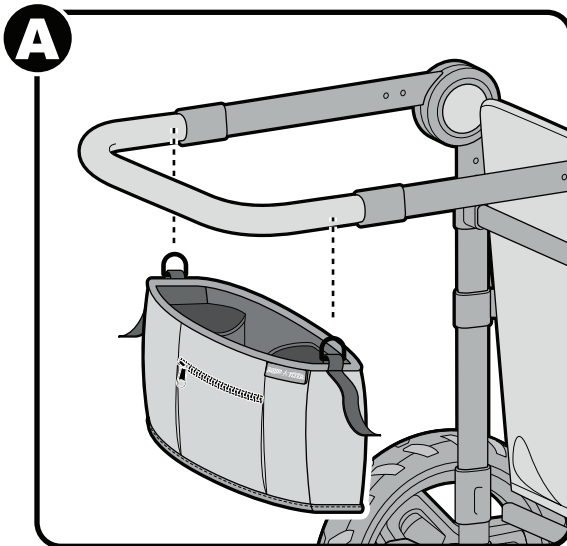

- ⚠ Maximum weight the handle bag is designed to carry is 5.0 lbs (2.2 kg).
- ⚠ Le poids maximum le sac de poignée est conçu à porter est 2,2 kg.
- ⚠ Cantidad máxima de peso para la bolsa de mango es de 2,2 kg.

18

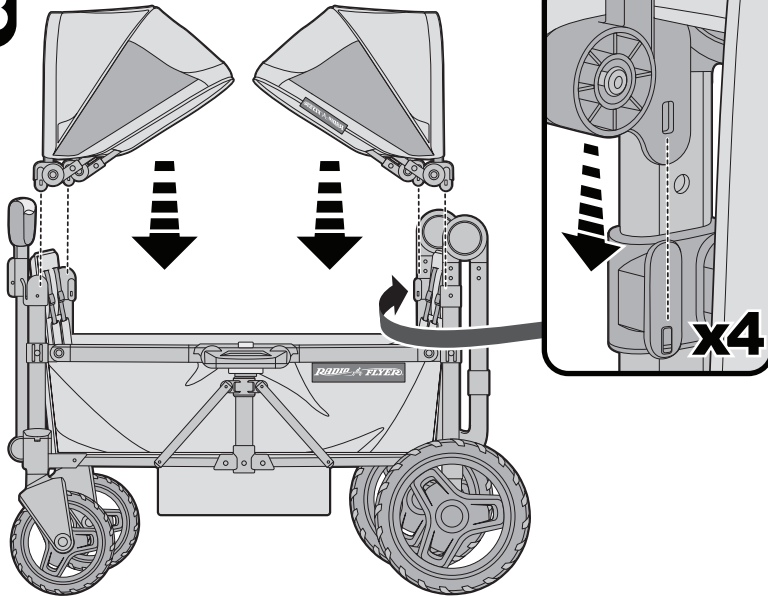

- Ensure mesh panel is pulled behind seatback.
- Assurez-vous que le panneau en filet se trouve derrière le dossier du siège.
- Asegúrese de que el panel de malla esté detrás del respaldo del asiento.

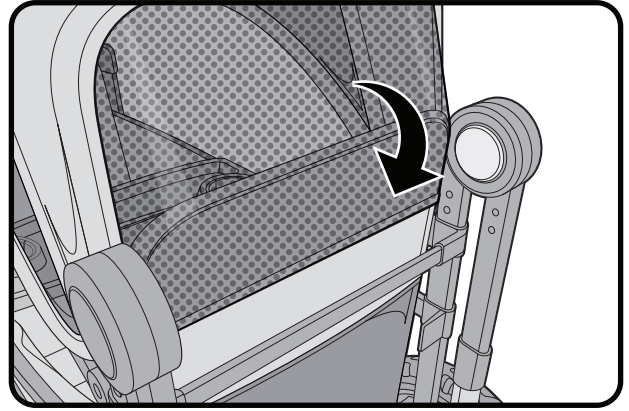

19

- To remove snack tray:
- Pour retirer le plateau snack:
- Para quitar la bandeja de bocadillos:

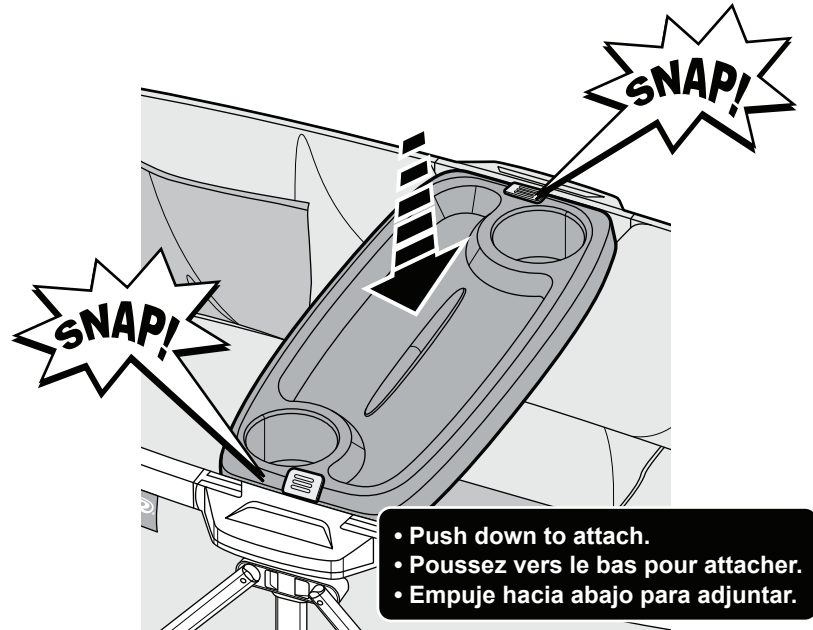
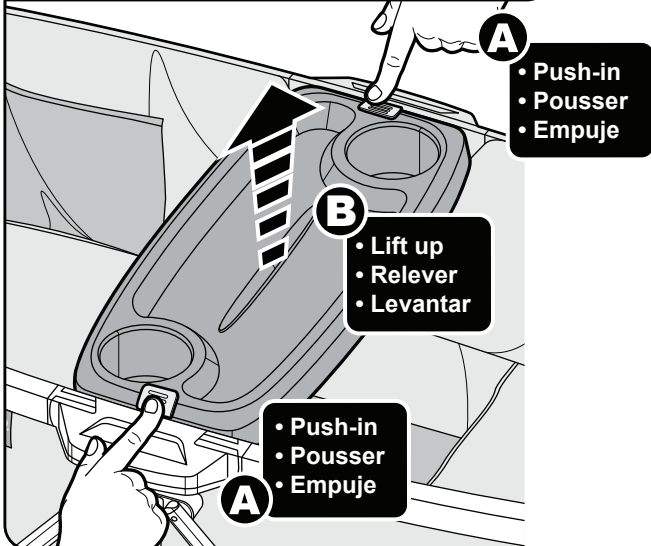

20

- ⚠ **CAUTION:** Use harness to secure child to wagon seat. **WARNING:** Avoid serious injury from falling or sliding out. Always use 5-point safety harness. Do not leave wagon unattended when children are secured with seat straps.
- ⚠ **MISE EN GARDE :** Utilisez le harnais pour attacher l'enfant au siège de la voiture. **AVERTISSEMENT :** Évitez les blessures graves provoquées par une chute ou une glissade. Utilisez toujours un harnais de sécurité à 5 points. Ne laissez pas la voiture sans surveillance lorsque des enfants sont attachés avec les courroies du siège.
- ⚠ **PRECAUCIÓN:** Use el arnés para asegurar al niño al asiento del carro. **ADVERTENCIA:** Evite lesiones graves por caídas o resbalones. Siempre use un arnés de seguridad de 5 puntos. No deje la carretilla descuidada cuando los niños estén asegurados con las correas del asiento.

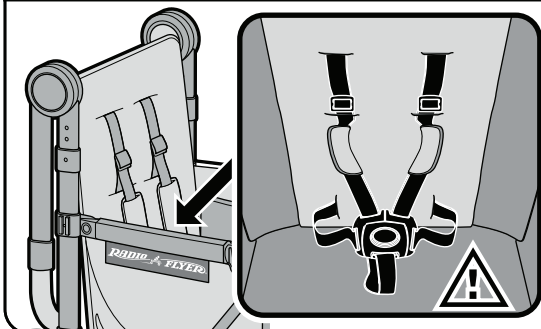

- Adjustable 5-point harness to grow with your child.
- Harnais réglable à 5 points pour grandir avec votre enfant.
- Arnés ajustable de 5 puntos para crecer con tu niño.

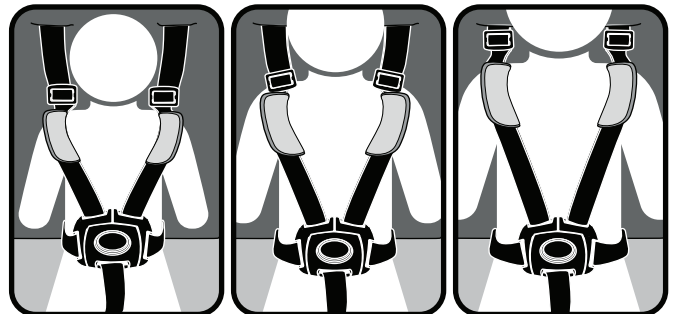

21 • To adjust pull handle height:
 • Pour régler la hauteur de la poignée de traction:
 • Para ajustar la altura del tirador:

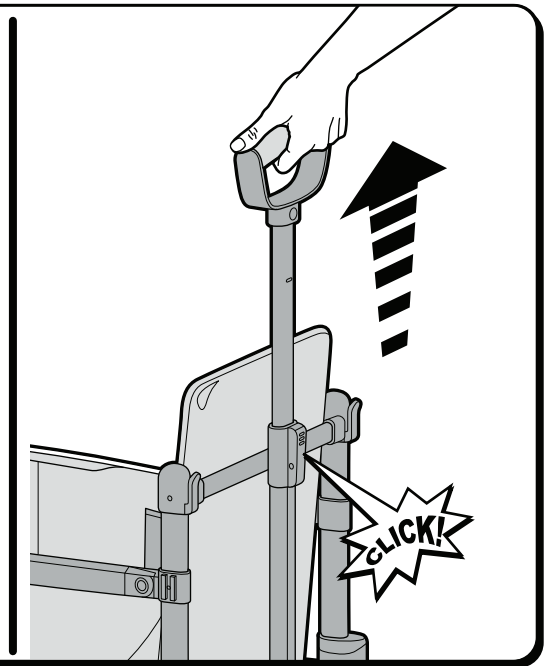
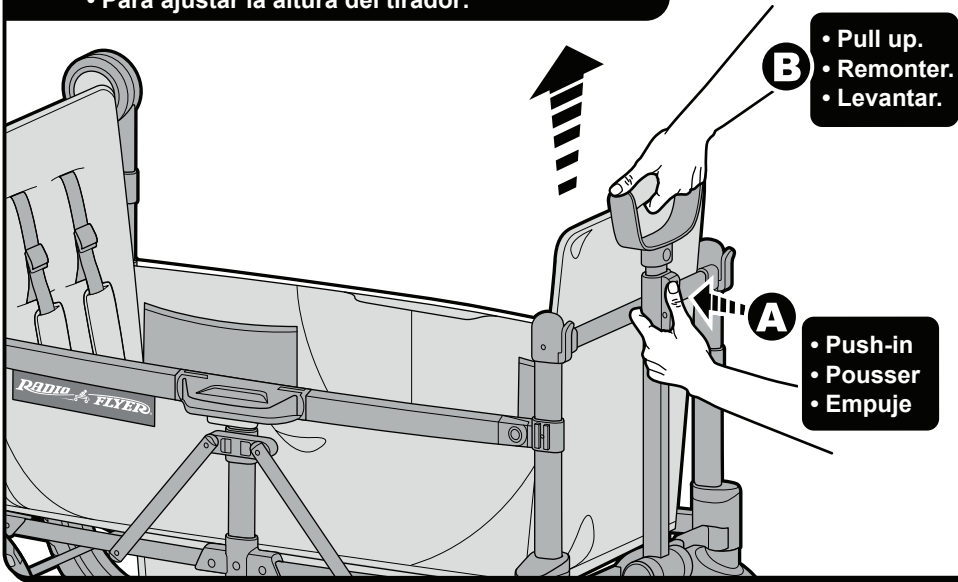

22 • To adjust push handle:
 • Pour ajuster la poignée de poussée:
 • Para ajustar el mango de empuje:

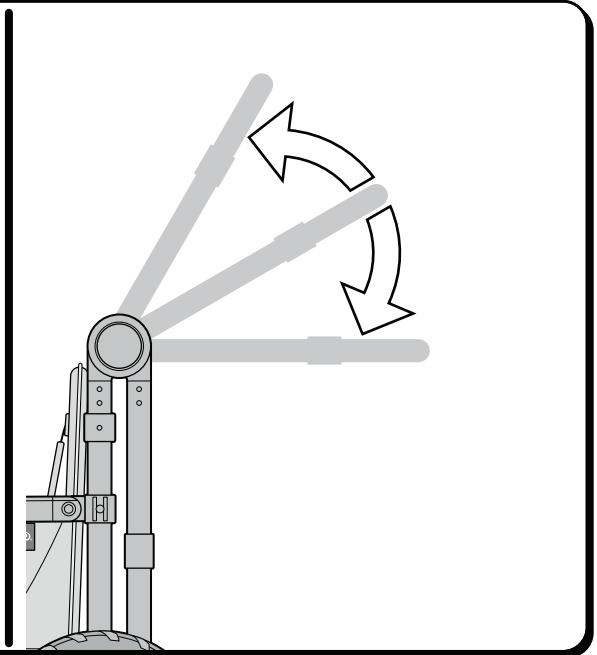
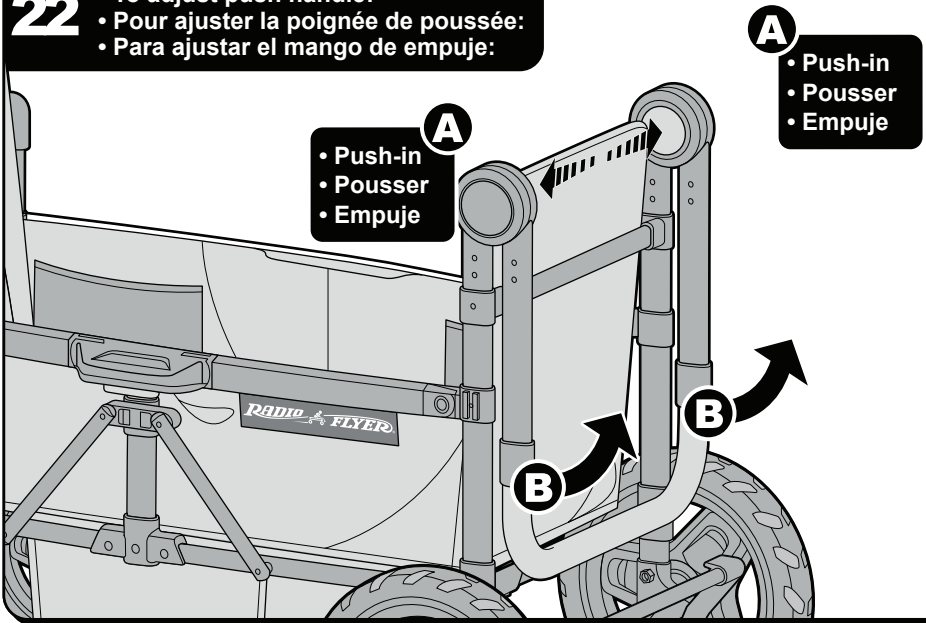

23 • Using the wheel brake:
 • Utiliser le frein de roue :
 • Utilice el freno de rueda:

• To engage brake, push bar down.
 • Pour engager le frein, poussez la barre vers le bas.
 • Coloque la correa de velcro antes de usar la carretilla.

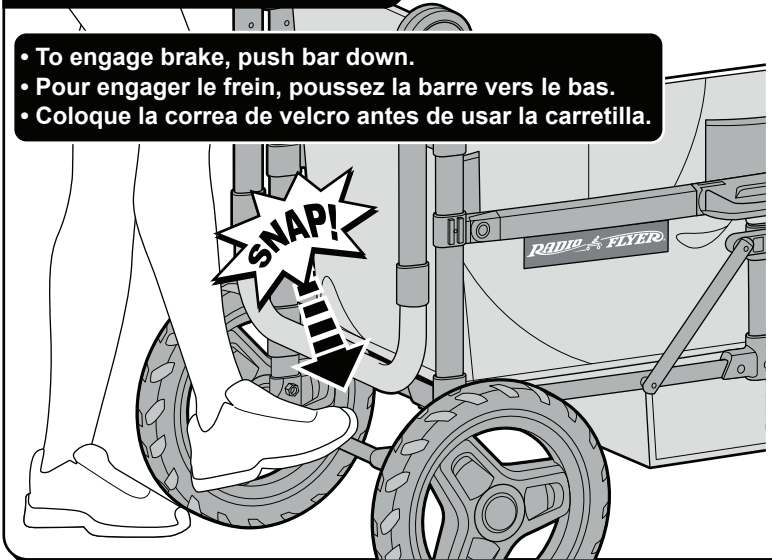

• To release the brake, pull up on bar.
 • Pour dégager le frein, soulevez la barre.
 • Para liberar el freno, levante la barra.



- Canopy storage:
- Stockage de la verrière:
- Almacenamiento del dosel:

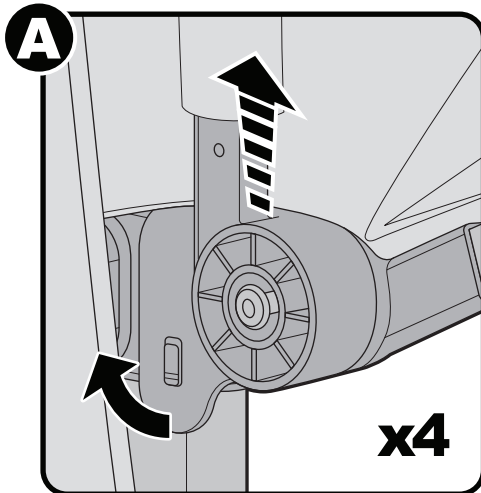

- Pull tab inwards and lift up to remove canopy.
- Tirez la languette vers l'intérieur et soulevez-la pour retirer la capuche.
- Jale la lengüeta hacia adentro y levántela para quitar la cubierta.

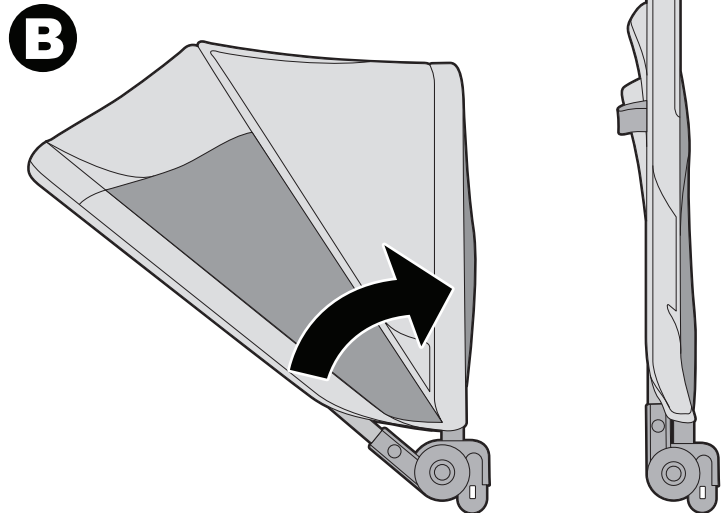

- Fold canopy flat.
- Pliez la capuche à plat.
- Doblar la cubierta plana.

C

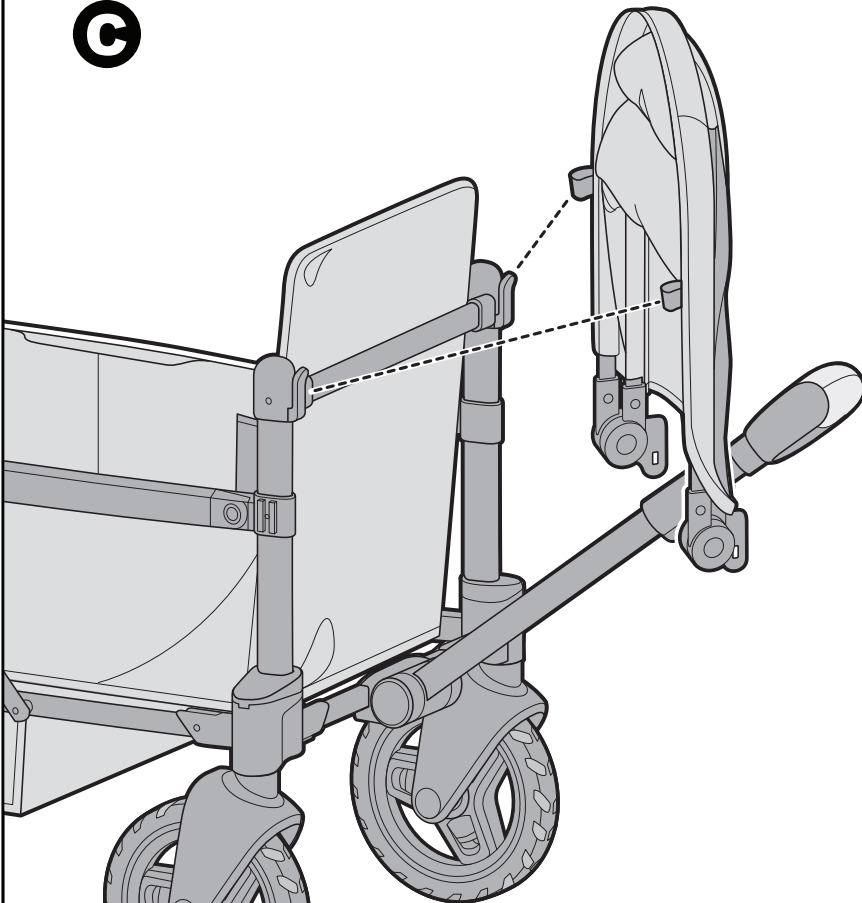

- Using two nylon loops, place each canopy on hooks on front of wagon.
- À l'aide de deux boucles en nylon, placez chaque auvent sur les crochets à l'avant du chariot.
- Usando dos bucles de nailon, coloque cada toldo en los ganchos en la parte delantera del vagón.

- Both canopies can be placed over the hooks at the same time.
- Les deux auvents peuvent être placés sur les crochets en même temps.
- Ambos toldos se pueden colocar sobre los ganchos al mismo tiempo.

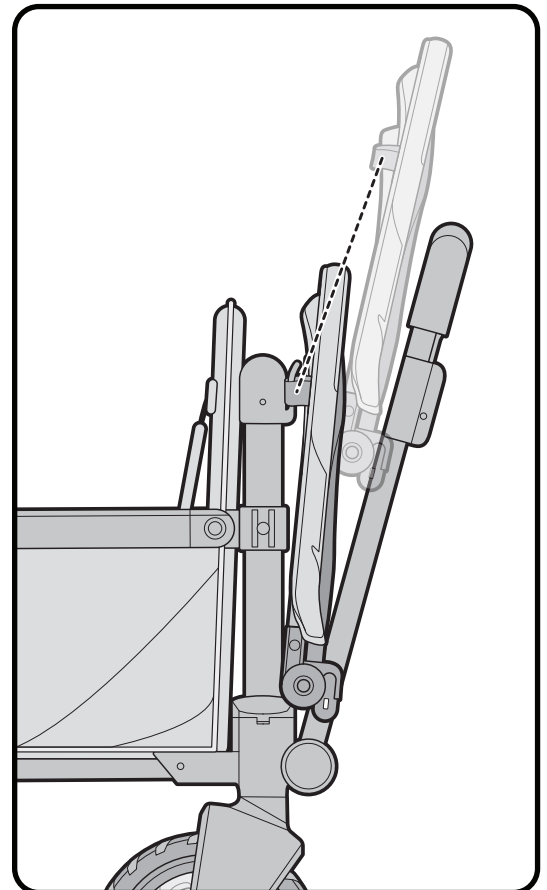

25

- For compact storage:
- Pour un rangement compact:
- Para un almacenamiento compacto:

- Push-in
- Pousser
- Empuje

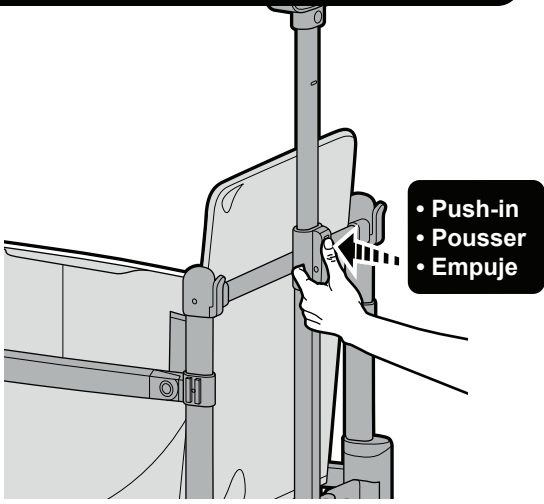

- Push-in
- Pousser
- Empuje

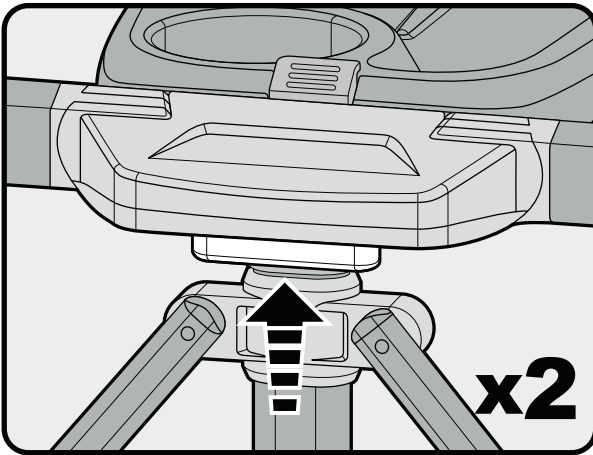
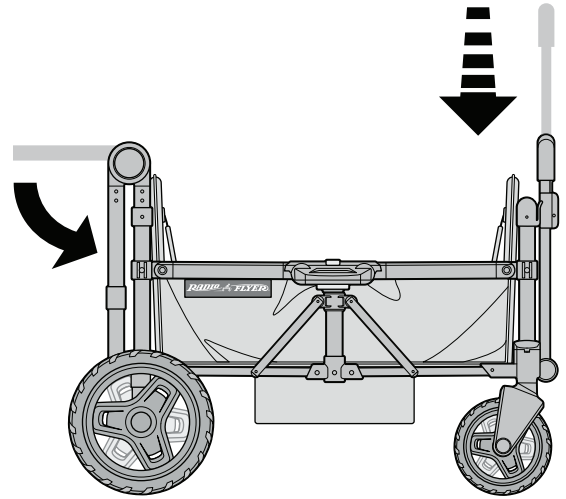
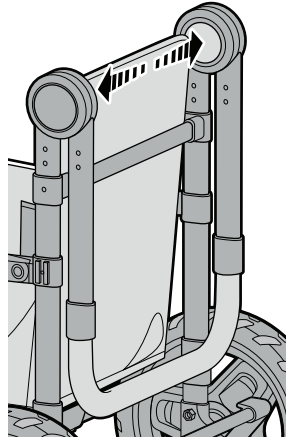

x2

- Press button.
- Appuie sur le bouton.
- Presiona el botón.

- Pull up.
- Tirer vers le haut.
- Levantarse.

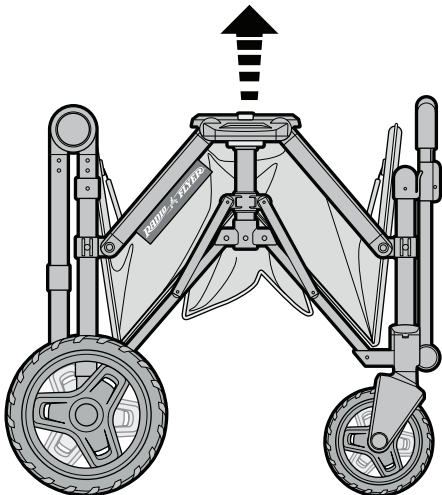
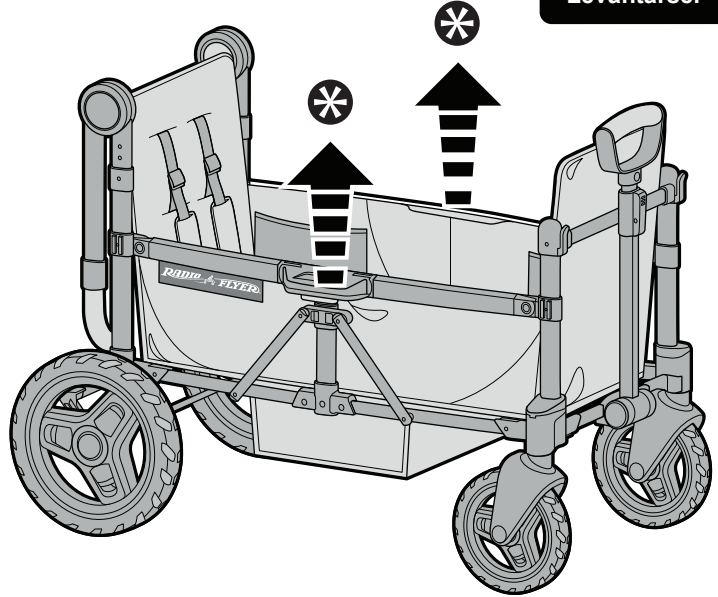

- Push-in
- Pousser
- Empuje

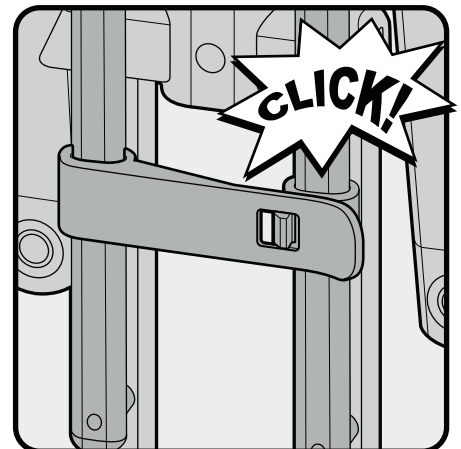
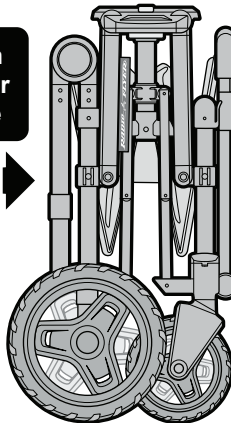

⚠️ WARNING:**TO AVOID SERIOUS INJURY:**

- Never leave child unattended. Continuous adult supervision is required.
- Avoid serious injury from falling or sliding out. Always use 5 pt safety harness.
- To prevent falls or injuries, children must remain seated with their arms and legs inside the wagon while riding.
- Never use near motor vehicles, streets, roadways, alleys, swimming pool areas, hills, steps, sloped driveways, inclines and public highways.
- Apply brake when taking children in or out.
- Only for children 6 months or older.
- Maximum weight this wagon is designed to carry is 120.0 lbs (54.4kg) inside wagon
- Maximum weight that can be carried in rear storage bag is 20.0 lbs (9.0kg).
- Maximum loading capacity of push handle-mounted bag is 5.0 lbs (2.25kg).
- Maximum weight that can be carried in front and rear mesh pockets is 2.0 lbs (0.9kg).
- Maximum weight that can be carried on child tray is 5.0 lbs (2.25kg).
- Maximum weight that can be carried in cupholder is 2.0 lbs (0.9kg).
- Never place hot beverages in cupholder, child tray, push handle-mounted bag, or any other location on wagon.
- Do not exceed maximum weight of 120.0 lbs (54.4kg) and maximum height of 48 in (122cm) or product may become unstable.
- Do not hang items on the handlebar or place them on the canopy as they can tip product over and injure child.
- Do not allow child to sit on or crawl over child tray
- No more than 2 riders at a time.
- Never use the wagon outside at night.
- Never use in wet weather.
- Excessive weight may cause a hazardous or unstable condition.
- Unfold and lock wagon in riding position before use.
- Only adults should fold and unfold the wagon.
- Always take care when folding and unfolding the product to prevent finger entrapment.
- This product is not intended for sleep or laying down. Do not use product as a carriage or bassinets.
- Do not use this product while jogging or running.
- If a bag other than the bag included with this product is attached to the product, the wagon may become unstable.

⚠️ AVERTISSEMENT:**POUR ÉVITER TOUTE BLESSURE GRAVE:**

- Ne laissez jamais un enfant sans surveillance. Une supervision continue par un adulte est requise.
- Évitez les blessures graves provoquées par une chute ou une glissade. Utilisez toujours un harnais de sécurité à 5 points.
- Pour empêcher les chutes et les blessures, les enfants doivent rester assis les bras et les jambes à l'intérieur de la voiture lors de sa conduite.
- N'utilisez jamais près de véhicules motorisés, rues, routes, allées, zones de piscines, collines, marches, entrées en pente, inclinaisons et autoroutes publiques.
- Appliquez le frein lors de l'entrée ou la sortie d'enfants.
- Seulement pour les enfants de 6 mois et plus.
- Le poids maximal que ce wagon est conçu pour transporter est de 120,0 lb (54,4 kg) à l'intérieur du wagon
- Le poids maximal pouvant être transporté dans le sac de rangement arrière est de 20,0 lb (9,0 kg).
- La capacité de charge maximale du sac monté sur la poignée de poussée est de 2,25 kg (5,0 lb).
- Le poids maximum pouvant être transporté dans les poches avant et arrière en filet est de 2,0 lb (0,9 kg).
- Le poids maximum pouvant être transporté sur le plateau pour enfant est de 5,0 lb (2,25 kg).
- Le poids maximum pouvant être transporté dans le porte-gobelet est de 2,0 lb (0,9 kg).
- Ne placez jamais de boissons chaudes dans le porte-gobelet, le plateau pour enfant, le sac monté sur la poignée de poussée ou tout autre emplacement sur le chariot.
- Ne dépassez pas le poids maximal de 120,0 lb (54,4 kg) et la hauteur maximale de 48 po (122 cm), sinon le produit pourrait devenir instable.
- Ne suspendez pas des articles sur le guidon, ni ne les placez sur l'auvent, car ils peuvent faire basculer le produit et blesser un enfant.
- Ne laissez pas l'enfant s'asseoir ou ramper sur le plateau pour enfant
- Pas plus de deux enfants à la fois.
- N'utilisez jamais la voiture dehors la nuit.
- Ne l'utilisez jamais lorsqu'il pleut.
- Dépliez et bloquez la voiture en position de conduite avant son utilisation.
- Seuls des adultes doivent plier et déplier la voiture.
- Veillez toujours à ne pas vous coincer les doigts lors du pliage et du dépliage du produit.
- Ce produit n'est pas conçu pour y dormir ou s'y reposer. N'utilisez pas ce produit comme un chariot ou une couchette.
- N'utilisez pas ce produit tout en joggant ou en courant.
- Laver la surface du tissu avec de l'eau chaude et un savon doux. No pas laver le tissu à la machine.
- Si un sac autre que celui fourni avec ce produit est attaché au produit, le chariot peut devenir instable.

⚠️ ADVERTENCIA:**PARA EVITAR LESIONES GRAVES:**

- Nunca descuide al niño o niña que lo acompaña. Es necesaria una supervisión constante por parte de un adulto.
- Evite lesiones graves por caídas o resbalones. Siempre use un arnés de seguridad de 5 puntos.
- Para evitar caídas o lesiones, los niños deben permanecer sentados con los brazos y las piernas dentro de la carretilla mientras viajan.
- Nunca lo use cerca de vehículos motorizados, calles, caminos, callejones, áreas de piscinas, colinas, escalones, caminos inclinados, pendientes y carreteras públicas.
- Use el freno al dejar salir o ingresar niños.
- Solo para niños de 6 meses o mayores.
- El peso máximo que este vagón está diseñado para transportar es de 120,0 lb (54,4 kg) dentro del vagón
- El peso máximo que se puede transportar en la bolsa de almacenamiento trasera es de 20,0 lb (9,0 kg).
- La capacidad de carga máxima de la bolsa montada en el asa de empuje es de 2,25 kg (5,0 lb).
- El peso máximo que se puede llevar en los bolsillos de malla delanteros y traseros es de 2,0 libras (0,9 kg).
- El peso máximo que se puede llevar en la bandeja para niños es de 5,0 libras (2,25 kg).
- El peso máximo que se puede transportar en el portavasos es de 0,9 kg (2,0 lb).
- Nunca coloque bebidas calientes en el portavasos, la bandeja para niños, la bolsa montada en el asa de empuje ni en ningún otro lugar del vagón.
- No supere el peso máximo de 54,4 kg (120 lb) y la altura máxima de 122 cm (48 in) o el producto podría volverse inestable.
- No cuelgue artículos en la barra de agarre ni los coloque en el dosel, ya que pueden voltear el producto y lesionar al niño.
- No permita que los niños se sienten o gateen sobre la bandeja para niños
- No más de 2 ocupantes a la vez.
- Nunca use la carretilla por la noche.
- Nunca la use en tiempo húmedo.
- Despliegue y asegure la carretilla en posición de conducción antes de usar.
- Solo los adultos deben plegar y desplegar la carretilla.
- Siempre tenga cuidado al doblar y desplegar el producto para evitar que los dedos queden atrapados.
- Este producto no está destinado para dormir o acostarse. No utilice el producto como un coche o cuna.
- No utilice este producto mientras trota o corre.
- Si se coloca en el producto una bolsa que no sea la que se incluye con este producto, el vagón puede volverse inestable.

MAINTENANCE INSTRUCTIONS:

- Periodically check hardware and tighten if necessary. Replace worn or broken parts immediately.
- Surface wash fabric with warm water and mild soap. Do not machine wash fabric.

INSTRUCTIONS D'ENTRETIEN:

- Vérifiez périodiquement la quincaillerie et resserrez-la au besoin. Remplacez immédiatement les pièces usées ou brisées.
- Laver la surface du tissu avec de l'eau chaude et un savon doux. No pas laver le tissu à la machine.

INSTRUCCIONES DE MANTENIMIENTO:

- Revise periódicamente la estructura y asegúrela si es necesario. Reemplace inmediatamente las piezas gastadas o rotas.
- Lavar superficie del tejido con agua tibia y jabón suave. No lavar a máquina.