



FLYER™

FLYER™ VIA™

OWNER'S MANUAL

Welcome to the Flyer™ Fleet

Congratulations on your new Flyer™ Via™!

The Flyer™ line delivers a high-performance experience for riders of all ages, ranging from micromobility solutions for families to premium wheels for kids. As an extension of the Radio Flyer® brand, Flyer™ products are created with the same beautiful design and quality that has inspired our work for over a century. We hope your new Flyer™ Via™ offers a fun, sustainable, and convenient way to get out and explore your world.

We can't wait to see where your new ride takes you.

Cheers,

The Radio Flyer Team

Time Flies. Enjoy the Ride.®

ABOUT THIS MANUAL

This owner's manual contains details of your Flyer™ eBike including instructions for assembly, operating, and maintenance. To ensure safe use and prevent injury, please carefully read all information in this manual before use. Take time to familiarize yourself with your Flyer™ eBike before use.

While this owner's manual is meant to introduce you to your Flyer™ eBike, it is impossible to guide owners on every possible scenario when using a bicycle. There are inherent risks using any bicycle and it is the owner's sole responsibility to ensure safe riding. Always take responsibility for your own safety.

Please keep this manual for future reference. If you have any questions about your eBike, contact the Radio Flyer Customer Service Team. Our award-winning service team is committed to providing you with world class support, right from Chicago.

Phone: 1-800-621-7613

Email: customerservice@radioflyer.com

Customer Service Hours: 8am - 5pm CST, Monday through Friday

Flyer™ Service Website: flyer.radioflyer.com/customer-service

Table of Contents

Important Safety Instructions.....	7
Safety Warnings	7
Getting Started	8
Assembly Instructions.....	8
Accessories.....	19
Adjusting bike fit.....	20
Operating Instructions	22
Handlebar Display.....	22
Flyer™ Smartphone App.....	24
Flight Speed® Battery	25
Installing a Bluetooth GPS tag (Optional).....	31
Motor Control	32
Riding & Safe Operating Guidelines	33
Carrying Loads.....	33
Ride Safety Checklist.....	34
Maintenance	37
Moving & Storage	38
Troubleshooting.....	39
Warranty.....	43

INSTRUCTIONS PERTAINING TO RISK OF FIRE OR ELECTRIC SHOCK

The owner's manual provides important operation and maintenance instructions for your ebike. Read the owner's manual carefully before riding and save it for future reference. Failure to follow any instructions in the owner's manual may result in electric shock, fire, and/or serious injury.

Important Safety Instructions

SAFETY WARNINGS

 **WARNING!** When using this product, basic precautions should always be followed including the following:

- Read all safety warnings and instructions before using the product. Failure to follow warnings and instructions may result in serious injury or death.
- To reduce the risk of injury, close supervision is necessary when the product is near children.
- The owner's manual provides important operation and maintenance instructions for your ebike. Read the owner's manual carefully before riding and save it for future reference. Failure to follow any instructions in the owner's manual may result in electric shock, fire, and/or serious injury.
- Do not put fingers or hands near spokes or moving parts.
- The Flyer™ eBike is intended for persons 16 years of age and older. Always ensure riders have the physical coordination and skill to navigate the bicycle safely while managing road conditions, traffic and adhering to all laws for bicycle use. When transporting passengers on the rear rack, always use recommended Flyer™ Accessories.
- Please check local laws to confirm legal requirements for using your eBike. The Flyer™ eBike is meant for paved roads and sidewalks, not off-road conditions.
- Do not use the Flyer™ eBike at ambient temperatures less than 14°F (-10°C) or above 104°F (40°C)
- Do not use this product if the flexible power cord or output cable is frayed, has broken insulation, or any other signs of damage.
- The battery is intended to be charged when the ambient temperature is between 0°C (32°F) and 35°C (95°F). Never charge the battery when ambient temperatures are outside this range.

SAVE THESE INSTRUCTIONS

Getting Started

ASSEMBLY INSTRUCTIONS

The following steps provide a general overview of the assembly process for your eBike. It is recommended to consult a professional bicycle mechanic for assistance with your eBike's assembly, maintenance, and repair.



Visit flyer.radioflyer.com or contact customerservice@radioflyer.com for additional assistance assembling, using, repairing or maintaining your eBike.

⚠ WARNING! Incorrect assembly, maintenance, or use of your Flyer™ eBike can cause component failure, loss of control, serious injury, or death. Please note, the assembly and first fit of your Flyer™ eBike require special tools and mechanical skills. It is highly recommended that the assembly and adjustment are completed by a reputable bicycle mechanic when possible.

The following items are required for assembly:

- 2.5mm allen wrench (included)
- 3mm allen wrench (included)
- 4mm allen wrench (included)
- 5mm allen wrench (included)
- 6mm allen wrench (included)
- 8mm allen wrench (included)
- Combination 15mm/18mm Open-ended wrench (included)
- Scissors and/or flat-sided cutters
- Tire Pump
- Pedal Grease (recommended)
- Torque Wrench (recommended)

Step 1: Unpack your bike

Note: Due to the size and weight of the bike, it is recommended that two adults remove and lift the bike from the carton.

Using scissors or flat-sided cutters, cut the outer carton straps located on the exterior of the packaging. Unclip the carton clips located along the bottom edge on both sides the carton. Once the clips and straps are removed, the top carton can be lifted up and away, leaving the bike and lower tray intact on the floor. With all the packaging still attached, two adults should remove the bike from the tray and place it on a clean flat surface to continue unpacking.

Note: The three corrugated supports located at the rear wheel, kickstand plate, and front wheel should remain on the bike until instructed to remove them.

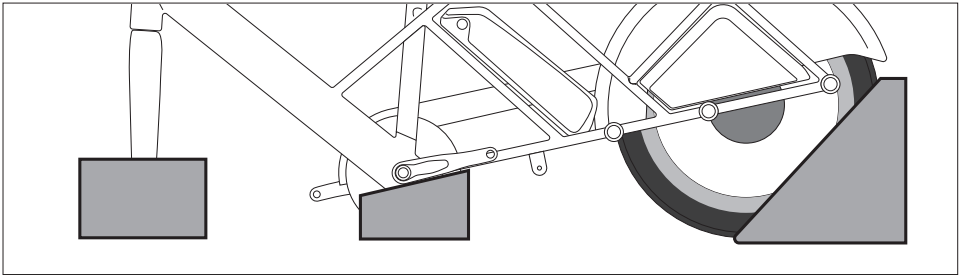

Contact Radio Flyer Customer Service if any components are missing.

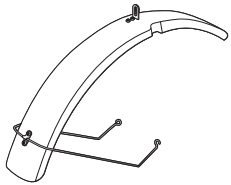
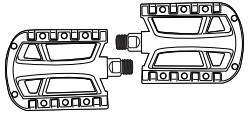
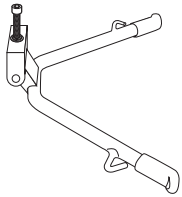
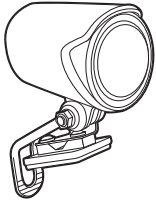
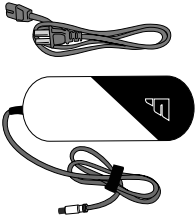
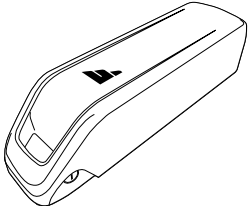
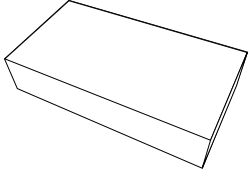
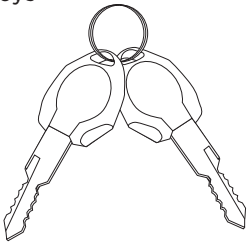
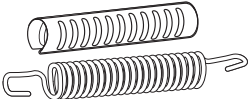
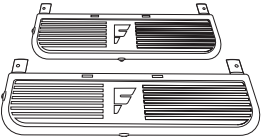
<p>Front Wheel</p> 	<p>Front Fender</p> 	<p>Pedals (Left & Right)</p> 
<p>Kickstand</p> 	<p>Headlight</p> 	<p>Charger</p> 
<p>Battery</p> 	<p>Hardware Box & Toolkit</p> 	<p>Keys</p> 
<p>Steering Assist Spring</p> 	<p>Running Boards (Left & Right)</p> 	

Step 2: Install the Kickstand

It's recommended that two adults are present during the completion of this assembly step to ensure the stability of the bike.

Note: With one adult supporting the bike, remove the packaging located beneath the kickstand mounting plate between the pedals and rear wheel.

- A. Using the provided 8mm Allen wrench, remove the kickstand bolt and washers. Set aside.
- B. Align the kickstand with the mounting plate located between the pedals and rear fender. Ensure the kickstand is oriented in the correct direction with the feet angled rearward, positioned below the chain.
- C. Install the kickstand bolt and washers through the mounting plate and into the top of the kickstand bracket. Tighten the bolt by hand.
- D. Fully tighten the kickstand bolt using the provided 8mm Allen wrench (Required Torque: 30 Nm). Deploy the kickstand.

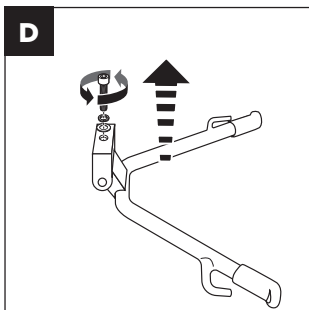
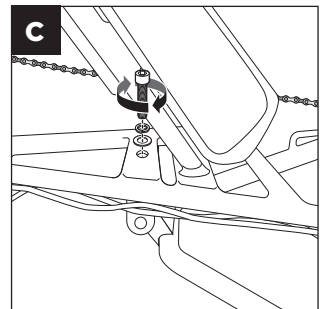
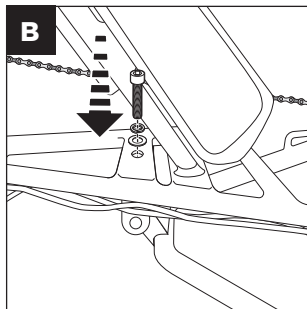
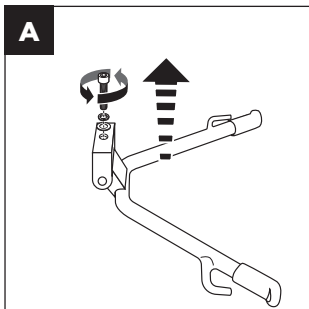

Step 3: Install the handlebars

- A. Using the 4mm allen wrench, loosen the four bolts and remove the handlebar clamp.
- B. Align the center of the handlebar in the clamp, using the marking as guides. Check the handlebar orientation matches the image below and that the cables are not twisted
- C. Reinstall the handlebar clamp and tighten the four bolts with the 4mm Allen wrench (Required Torque: 6-8 Nm). The gap between the clamp and stem should be even on the front and back after tightening.

Note: Complete the assembly of the bike per the steps below. The height of the stem and angle of the handlebars can be adjusted as needed based on rider preference. Always re-tighten bolts to their specified torque values prior to riding.

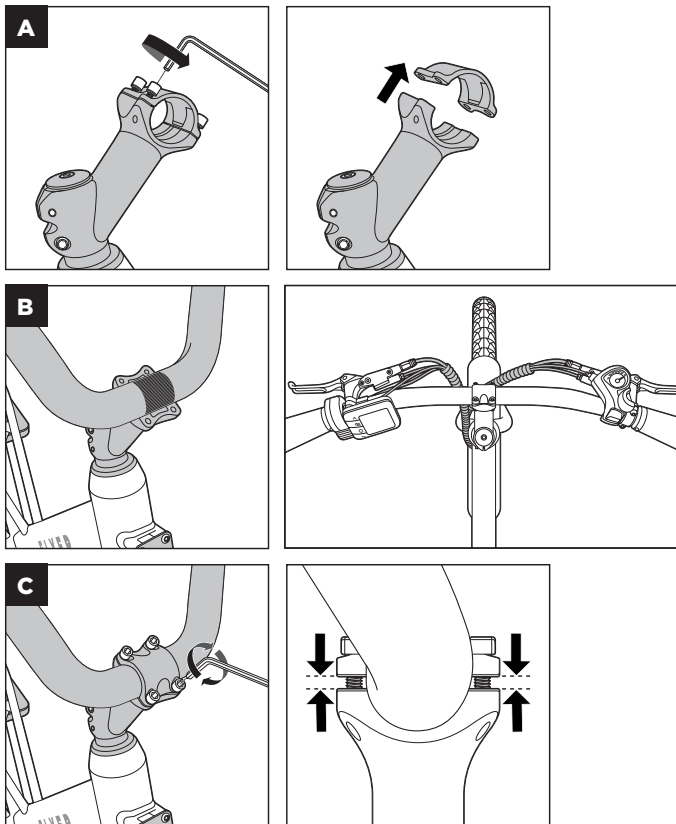

Step 4: Install the headlight



Note: If you plan to install a front accessory, like the Front Storage Basket, you should follow the instructions included with the front accessory as the mounting location will vary.

- A. Align the terminals on the headlight connector with the plug hanging from the bike
- B. Using the 4mm allen wrench, remove the screw and washer from the front of the fork. Set aside.
- C. Align the headlight bracket with the fork and reinstall the screw with washers using the 4mm allen wrench.
- D. The headlight angle can be adjusted to illuminate the road ahead, while ensuring the beam will not blind or obscure the vision of oncoming traffic or pedestrians.

Note: It is not recommended to ride at night. If riding at night cannot be avoided, ensure the headlight is always on and functioning correctly while you are riding.

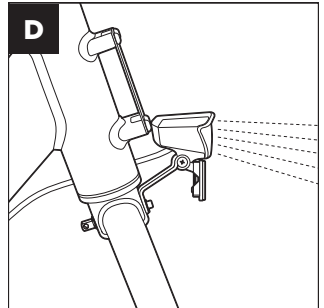
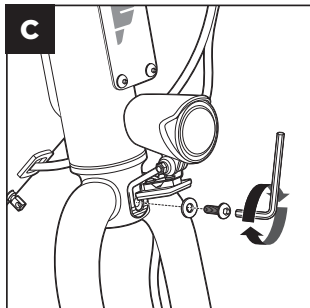
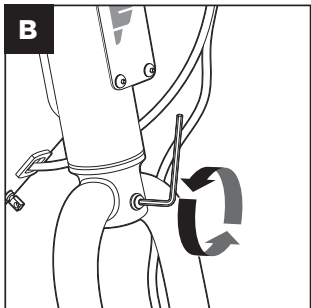
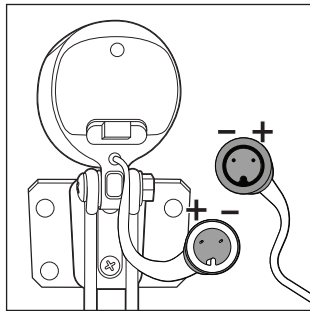
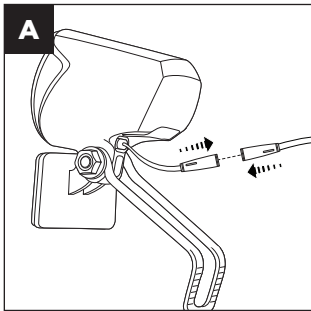

Step 5: Install the front fender

- A. Loosen the eye bolt at the top of the fork by hand. Remove eye bolt and washer and set aside.
- B. Using the 5mm Allen wrench, remove the screws on either side of the fork. Set aside.
- C. Position the fender inside the fork, lining up the bracket to the threaded hole in the top of the fork. Reinstall the eyebolt and washer. Tighten by hand.
- D. Align the fender frame stays with the threaded holes on either side of the fork. Re-install the screws and washers using the 5mm Allen wrench.

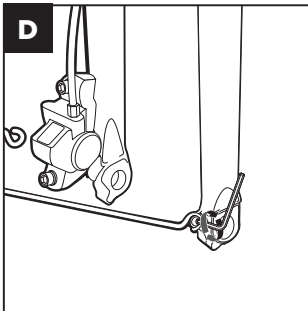
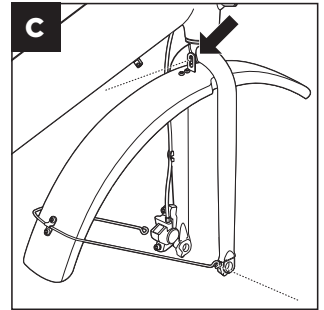
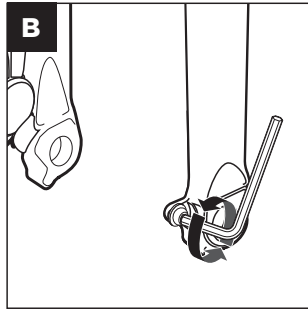
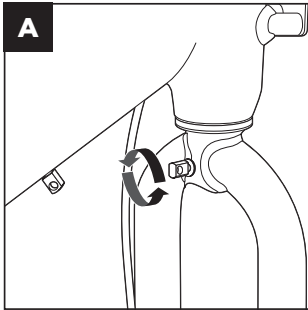

Step 6: Install the front wheel

The bike is shipped with an aluminum spacer installed in the fork dropouts to prevent damage during shipment. Prior to installing the front wheel this spacer must be removed by first disassembling the front axle skewer. Once removed, the aluminum spacer can be set aside. **Do not discard the front through-axle as it is needed to install the front wheel.**

- A. Remove the brake pad spacer from the front caliper before attempting to install the front wheel. While the spacer is removed, do not squeeze the front brake levers as it may damage the brake pads.
- B. Align the wheel to the fork so that the fork dropouts align on the axle. Ensure the wheel is centered on the fork, and the brake rotor is centered in the caliper assembly.
- C. Starting from the brake side of the fork, install the front through-axle by sliding it through the fork and front wheel hub. Tighten by hand.
- D. Tighten the front through-axle using the provided 6mm Allen wrench (Required Torque: 6-8 Nm).

Note: Touching the brake rotor or pads with bare skin can result in natural oils transferring to components which can result in reduced braking performance or noisy operation.

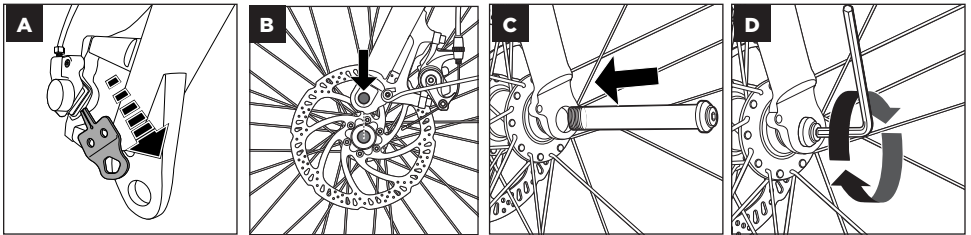

Step 7: Install the steering spring

- A. Install one side of the spring in the eyebolt on the frame.
- B. Using some force, extend the spring and install the opposite side in the eyebolt on the front fork. You will hear an audible snap when the spring is properly seated in the eyebolt.
- C. Install plastic protective sleeve around the spring.

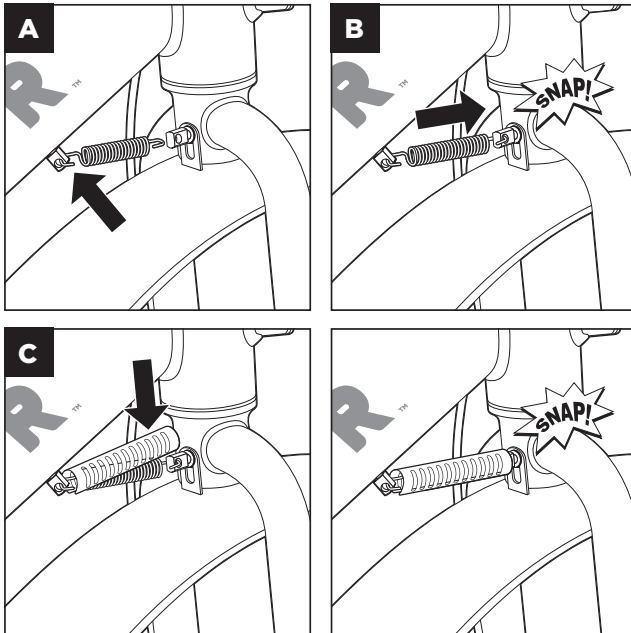

Step 8: Install the pedals



STOP! Properly identify the right and left pedals before assembling to avoid damage to the pedals or crank. The right pedal will have a smooth axle while the left pedal will have notches in the axle.

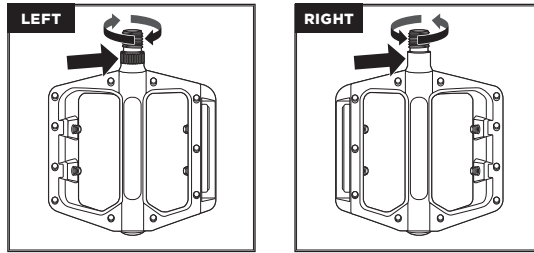

- Install the right pedal to the crank arm by turning the axle **clockwise** by hand.
- Install the left pedal to the crank arm by turning the axle **counter-clockwise** by hand.
- Use the provided 15mm combination wrench to torque both pedals
(Required Torque: 35 Nm)

Note: We recommend applying pedal grease to the threads prior to installation

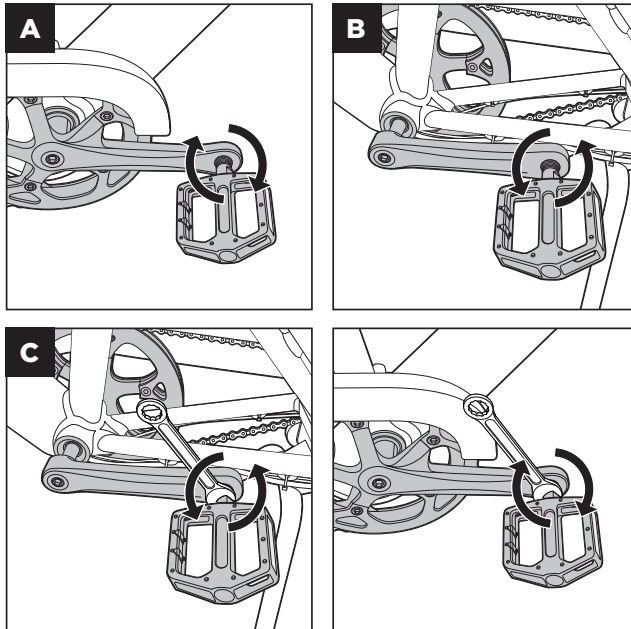

Step 9: Install the running boards

Note: The Left and Right Running Boards are identical and can be installed on the left or right side

- A. Using the 5mm allen key, remove the 4 M6 screws and washers from the bottom of the running boards. Set aside.
- B. Align the running board frame-ends with the receivers in the frame
- C. Ensure the alignment tabs on bottom edge of the triangle-shaped fender covers engage with the two cut-outs on the footboards. It may be necessary to lift the triangle cover up slightly with your hands to align the holes.
- D. Reinstall the screws and washers using the provided 5mm allen key.
- E. Fully tighten the screws (Required Torque: 10 Nm).

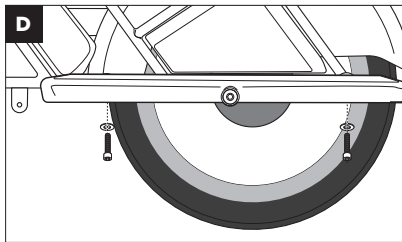
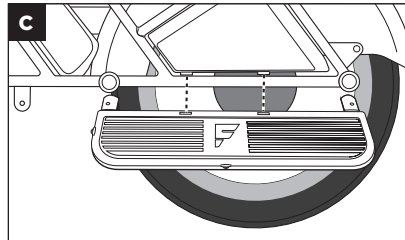
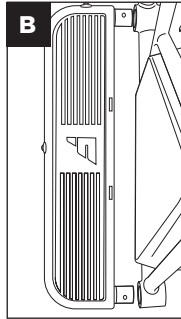
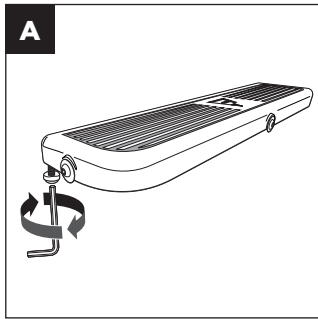

Step 10 (Optional): Installing a Bike Trailer

If you will be installing a bike trailer. Use an M12 Bolt + Nut to secure the adapter included with the bike trailer to the larger hole on the towing tab located on the brake-side of the bike.

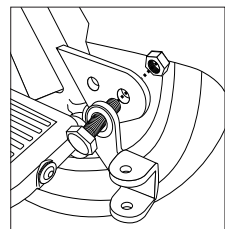

Step 11: Check fastener torque values

Area of Bike	Hardware	Torque (Nm)
Handlebar	Stem Clamp Bolts	6
	Brake Lever Clamp Bolts	6
	Stem Faceplate Bolts	6 to 8
	Stem Cover Bolt	6 to 8
Seat Post	Seat Mounting Bolts	10
Kickstand	Kickstand Bolt	30
Front/Rear Brakes	Disc Brake Rotor to Hub	8
	Caliper Adapter to Frame	6 to 8
	Caliper to Adapter	6 to 8
	Through-axle	6 to 8
Rear Dropout	Rear Axle Nuts	50
	Chain Tensioner Mounting Bolt	6
Bottom Bracket	Crank Arm Bolt	40
	Pedal into Crank Arm	35
	Chain Ring Bolts	8

Step 12: Inflate tires to 30psi



⚠ WARNING! It is important to maintain proper air pressure in the tires while riding. Do not overinflate or underinflate the tires. Overinflated tires may burst. Inflate your tires using an air source with a pressure gauge to avoid overinflation. Underinflated tires may impair the control of the eBike and cause a safety hazard.

ACCESSORIES

Radio Flyer carries a full line of custom accessories to enhance the usability of your eBike. Please refer to the instruction sheets provided with each accessory to ensure proper assembly. Visit flyer.radioflyer.com or contact customerservice@radioflyer.com for additional assistance assembling, using, or repairing your accessories.



⚠ WARNING! Incorrect installation of accessories can cause damage to the bike frame, loss of control, serious injury, or death.

ADJUSTING BIKE FIT

Adjusting Seat Height

The seat height should be set based on your personal preference. The initial seat position can be set by first placing the ball of your foot on the pedal with the crank arm in its lowest position. In this position, your leg should be almost fully extended with a slight bend in your knee. The proper seat position is important to avoid strain and potential injury during riding. Consult a trusted, reputable bike mechanic or contact Flyer customer service for any questions related to the seat position and fit of your bike.

⚠️ WARNING! The Seat post be inserted to the minimum insertion mark. Do not raise the seat post beyond the minimum insertion marking on the seat post tube. If the seat post is not inserted properly, the seat may be loose which can lead to serious injury or death

- A. Open the quick release lever located under the saddle. Rotate the lever fully open to allow the seat post to slide easily.
- B. Move the seat up and down by sliding the seat post in or out of the seat tube. Set the saddle to the desired height based on rider preference. Ensure that the seat post does not extend beyond the “minimum seat post insertion” markings on the seat post.
- C. Firmly close the quick release lever to secure the saddle in place.
- D. With the quick release lever closed, tighten the clamp screw to 10N-m.

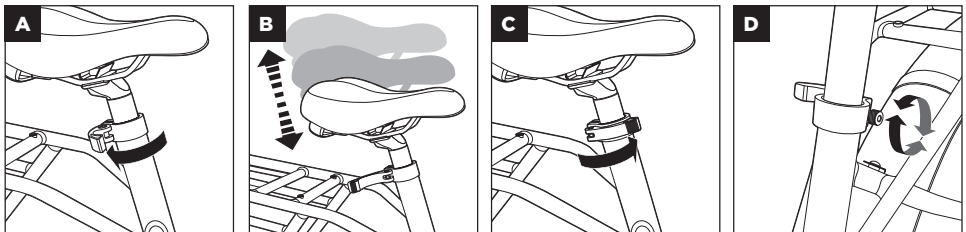

Adjusting Handlebar Rotational Position

Following any adjustment of the handlebar stem position, the handle bar rotational position should also be adjusted. Ensuring that the handgrips and brake levers are in the correct position will avoid any strain or discomfort while riding.

- A. Using the provided 4mm allen wrench, loosen the four stem clamp bolts.
- B. Rotate the handlebar until the preferred position is achieved checking to ensure the handlebar is centered left-to-right within the stem clamp.
- C. Evenly tighten the bolts to 6 to 8 Nm using a torque wrench. The spacing should be equal on the front and rear of the clamp.

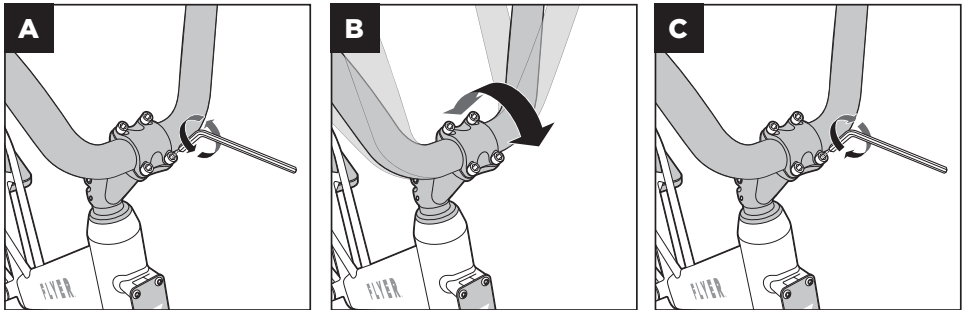

Operating Instructions

HANDLEBAR DISPLAY

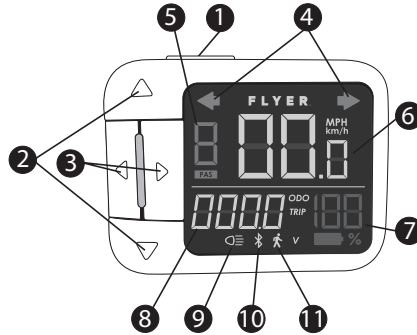

Display Controls

Location	Function	Operating Instruction
1	Turn Bike On/Off	Push and hold power on/off button
3	Left/Right Rear Turn Signal	Tap left/right turn signal button
2	Increase/Decrease Pedal Assist Level	Tap increase/decrease pedal assist button
2 (Bottom)	Enable Walking Mode	Push and hold the pedal assist decrease button
1	Cycle Odometer/Trip/Range/Voltage	Tap the power/on-off button
2 (Top)	Turn Headlight On/Off	Push and hold pedal assist increase button

Display Icons & Function

Location	Description
4	Turn Signal Indicators
5	Pedal Assist Level
6	Speedometer
7	Battery State-of-Charge (SoC)
8	Odometer/Trip/Range/Voltage
9	Headlight Status
10	Bluetooth Status
11	Walking Mode Status

Walking Mode

Walking mode is a feature to aid the user when walking the bike when the handlebar display is on. To enable walking mode, push and hold the pedal assist decrease button on the display. The motor will engage at a steady speed of approximately 3MPH. To turn off walking mode at any time, release the pedal assist decrease button or squeeze either hand brake to disable the motor.

Note: Walking mode should only be used while dismounted from the bike and with both hands on the handlebar. Always keep at least one hand on a brake lever to allow quick cutoff of the motor assistance if necessary.

Turn Signals

The rear taillight is equipped with LED turn signals which can be activated by tapping the left or right turn signal buttons on the display. They can be cancelled at any time by tapping the same turn signal button again. If the user does not cancel the turn signal, it will continue to blink for a set time duration which can be customized in the Flyer™ app.

Note: Hand-signals should always be used to alert other drivers, cyclists, or pedestrians who may not be able to see the turn LEDs from all angles.

Range Estimation

The display is equipped with range estimation capabilities which uses the current pedal assist level and state-of-charge to provide the rider with a best-case readout of the remaining range for the active battery.

Note: The range estimation can vary based on each specific scenario. Weather, Gearing Selection, Pedal Assist Level, Throttle Usage, and Terrain can all impact the reporting displayed on the display or in the app.

FLYER™ SMARTPHONE APP

In order to download the Flyer™ app for your Flyer™ Via™, scan the QR codes below or search “Flyer™” in the App Store or Google Play Store.

Power on the eBike and ensure your mobile device has Bluetooth turned on. Click “Connect to eBike” within the App and select your eBike’s serial number. The app will prompt you to review safe riding instructions. Review prior to riding.

The Flyer™ App allows you to change speed settings, turn the headlight on and off, lock the motor, access troubleshooting information, as well as update your firmware.



iPhone Users

Scan the QR code to download the Flyer™ app or go to apps.apple.com/us/app/flyer/id1576868032

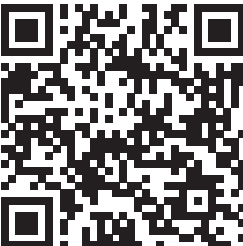

Android Users

Scan the QR code to download the Flyer™ app or go to play.google.com/store/apps/details?id=com.radioflyer.flyer

FLIGHT SPEED® BATTERY

Battery and Charger Safety Warnings

WARNING! TO PREVENT FIRE, EXPLOSIONS, OR ELECTRIC SHOCK:

- Before using the battery read all instructions and cautionary markings on the charger and battery pack.
- Only use the specified Flyer™ charger (Model BC311480020-T, made by MDA Power Technology Co limited) to charge this battery. Do not attempt to charge with any other chargers. Replacement chargers are available to purchase exclusively at flyer.radioflyer.com or by calling Radio Flyer Customer Service at 1-800-621-7613.
- Do not store the battery in locations where the temperature is below 14°F (-10°C) or above 104°F (40°C)
- Do not charge the battery in temperatures below 32°F (0°C) or above 95°F (35°C). The battery will not charge outside of these temperate limits.
- Do not operate the charger or battery if it has been impacted, dropped, or damaged in any way.
- Do not use if the power cord is frayed, has broken insulation, or any other signs of damage.
- If the plastic on the battery breaks or cracks, stop use and call Radio Flyer Customer Service.
- Examine the charger and battery before each use and replace if wear or damage is found.
- Do not incinerate the battery pack. The battery can explode in a fire.
- Never attempt to open or disassemble the battery pack or charger for any reason. Do not puncture the battery.
- To prevent electric shock, do not immerse the charger or battery in water.
- Do not attempt to charge if the cord or power adapter is wet.
- To clean, remove the charger/battery plug from the outlet and wipe with a dry cloth.

- During charging, the battery must be placed on a flat surface in a dry ventilated area.
- Do not place any object on top of the charger or place the charger on a soft surface that may result in excessive heat. Place the charger away from any heat sources.
- The charger is designed to operate on a standard household electrical power (110/120 VAC). Do not attempt to use the charger on any other voltage level.
- To reduce the risk of fire, connect only to a circuit provided with 20A amperes maximum branch circuit overcurrent protection in accordance with the National Electrical Code, ANSI/NFPA 70.
- When charging is complete, disconnect the charger from the wall outlet and the battery.
- Place the battery and charger in a place out of reach from children.
- To increase battery life, recharge after every use.
- To maintain battery life, you must charge every 6 months.

Charging the Battery

The Flight Speed® battery can be charged while installed in the bike or when removed from the bike frame.

- A. Ensure the battery is off by powering off the display as described in the “Handlebar Display” section above.
- B. Lift the rubber cover to reveal the battery charging port.
- C. Plug the charger into the battery charging port. Push the charger plug firmly into the charging port.
- D. Plug the charger into a power outlet. Only connect your charger to an outlet with a rated voltage of 120-240VAC. The LED in the charger housing will turn red to indicate the charger is connected properly.
- E. Once the charger LED turns green (indicating the battery is fully charged), unplug the charger from the power outlet.
- F. Unplug the charger plug from the charging port and replace the rubber cover.

Note: Before the first-ride, the battery should be fully charged to ensure accurate calibration of the battery and bike electrical systems.

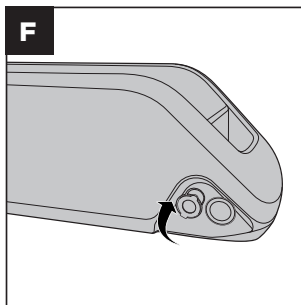
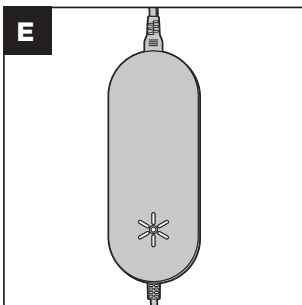
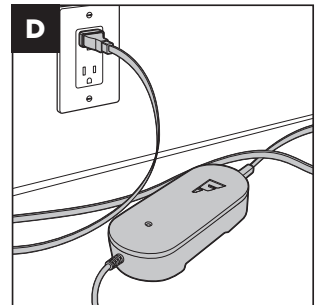
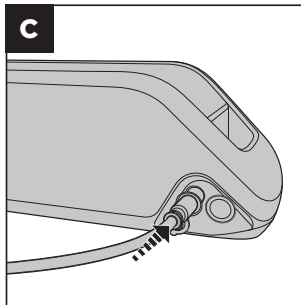
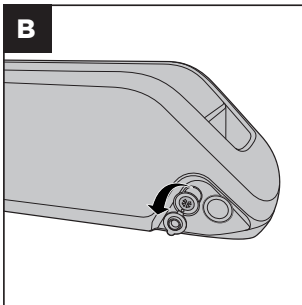

Removing the Battery

Note: The battery should only be removed when the bike is stationary and powered off.

Failure to do so could result in damage to the battery or electrical system of the bike.

- A. Insert the provided key into the battery lock. If you own multiple Flyer™ bikes, please ensure the 3-digit codes on the key and lock are matching.
- B. Turn the key clockwise to release the battery latch.
- C. Remove the battery by sliding it vertically until it disengages from the dock rail.
- D. Slide the battery outward between the rear frame as shown in the image below.

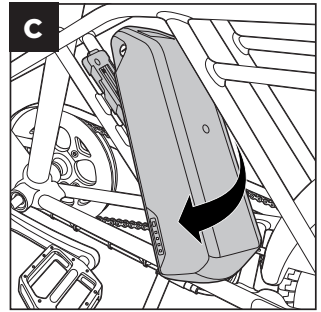
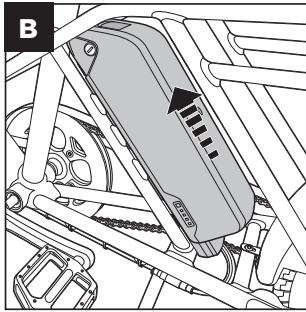
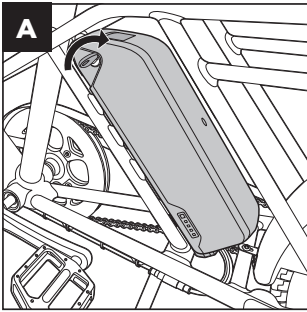

Installing the Battery

- A. Slide the battery between the rear frame as shown in the image below.
- B. Align the battery pack with the dock rail ensuring both sides are properly engaged.
- C. Slide the battery downward along the dock rail. Push firmly until you hear an audible click indicating the battery is fully installed.

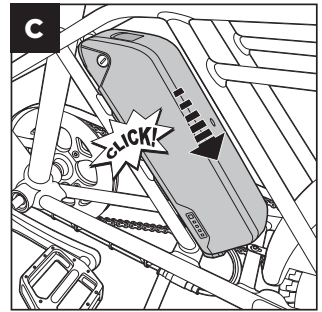
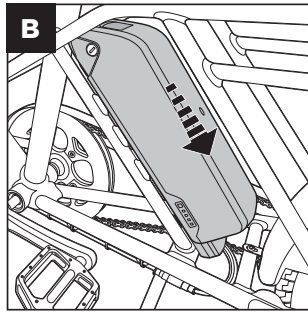
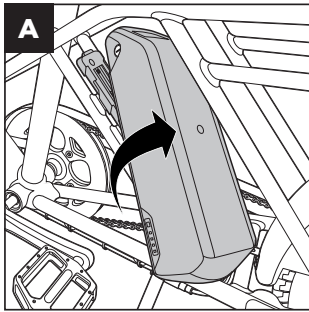

Checking the Battery Charge Level

In addition to the main display, the battery charge level can also be checked directly on the battery.

- A. Remove the battery following the steps outlined in the “Removing the Battery” section.
- B. Locate the battery fuel gauge at the top of the battery.
- C. Push the button on the battery fuel gauge. Fuel gauge LEDs will light up corresponding to the level of charge in the battery pack.

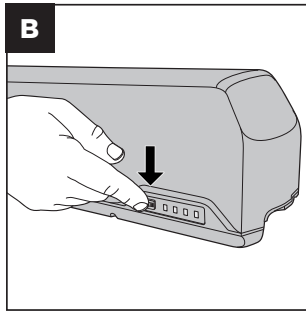
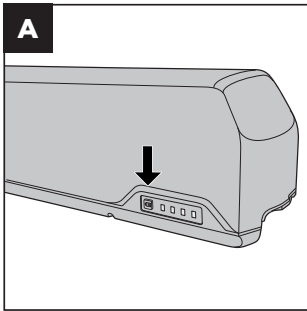

INSTALLING A BLUETOOTH GPS TAG (OPTIONAL)

The bike includes a holder that can house one Bluetooth location tag as a security feature. The tag must be purchased separately and activated prior to installation. For a list of compatible tags, visit flyer.radioflyer.com or contact customerservice@radioflyer.com

- A. Remove the battery as described in the previous step “Removing the battery”
- B. Align the Bluetooth GPS Tag with the circular cut-out area on the dock. Snap the Bluetooth GPS Tag into place.

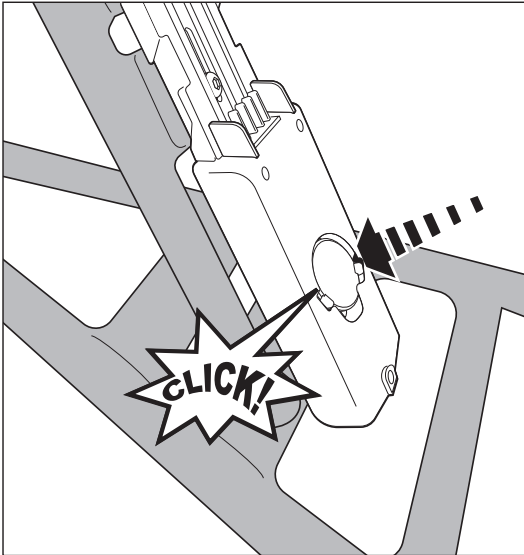

MOTOR CONTROL

Pedal Assist System (PAS)

The pedal assist system (PAS) augments your natural pedaling action by providing an additional boost from the motor. Using the PAS increase and decrease buttons, you can control the level of assistance provided by the motor. As the PAS level is increased, the amount of assistance increases and the faster you will go. The PAS setting will depend on several factors including, but not limited to:

- Riding terrain (flat vs. incline)
- Total payload
- Desired range

The gear shifter will not affect the performance of the hub motor or pedal assist system, however it will affect the amount of resistance you feel. Lower gears provide less resistance with a higher pedaling cadence. Higher gears provide more resistance and a slower pedaling cadence. Some experimentation will be necessary to dial in the combination of PAS level and gear setting that offers a smooth ride based on your preference.

Throttle

The throttle provides an alternate way to power the motor if you do not want to pedal. If the bike is powered on, the throttle can be activated by slowly pushing the throttle lever downward. The throttle can also be used in addition to the pedal assist system. When only using the throttle, the maximum speed of the bike will be capped at 20MPH.

Notice: Using the bike in throttle-only mode will negatively impact the range of the battery vs. using pedal assist.

 **WARNING!** Do not twist the throttle when dismantled to avoid accidental acceleration of the bike

Riding & Safe Operating Guidelines

It is the owner's sole responsibility to ensure safe riding. Among other things:

- Always obey road and traffic laws as applicable in your local area.
- Before riding in more dynamic conditions, practice and familiarize yourself with the operations of the eBike, including braking, pedal assist, and throttle.
- Always wear a helmet that meets the US CPSC standard. Wearing a helmet can prevent head injuries.
- After a crash or an incident, do not ride your eBike until you have a certified and reputable bike mechanic inspect the eBike to ensure proper function of the eBike and all its components.
- It is recommended not to ride at night or in wet weather. Ride at night and in wet weather only if necessary.
- If it is unavoidable to ride at night or in wet weather:
 - Wear reflective or light-colored clothing
 - Ride slowly with caution
 - Ensure the headlight and brake light are powered on and functioning properly

 **WARNING!** The Flyer™ eBike is not meant for use in wet conditions. Water intrusion can damage the eBike's electrical system and cause battery failure, electrical system malfunction, or fire.

CARRYING LOADS

The total maximum payload capacity of the Flyer™ Via™ eBike is 400lbs (181kg). This includes the weight of the rider, as well as any passengers, cargo, accessories etc.

Maximum rider weight: 220lbs (99kg)

Rear rack maximum loading weight: 150lbs (68kg)

Always reference the maximum weight capacity of any accessories used as well.

Ride Safety Checklist

Component	
Torque Values	<ul style="list-style-type: none"> Reference the torque chart in assembly step 10 to check the torque on all fasteners listed.
Brakes	<ul style="list-style-type: none"> <i>Note: The brakes may require re-tuning after final assembly is complete and should be tuned again after the first 50-100 miles by a reputable bike mechanic along with regular maintenance.</i> Verify the front and rear brakes function properly. Pads should fully cover the brake disc once lever is pulled. To confirm brake contact, verify that the brake disc moves slightly once the level is pulled. Ensure the brake light illuminates once brake lever is pulled. Check brake lines to confirm there is no wear or deterioration and they are properly lubricated and tensioned. Check brake pads to ensure they are not over-worn. Ensure the lever system is secured to the handlebar (torque: 6Nm). Check for any leaks in the hydraulic lines, calipers, or levers.
Tires	<ul style="list-style-type: none"> Confirm the tires are inflated to 30 PSI. Check tires for leaks, signs of wear, tread degradation, or other compromising damage.
Wheels	<ul style="list-style-type: none"> Verify wheel spokes are tight on both ends with no bending. Ensure tires and rims rotate straight without wobble. Confirm the rear wheel axle nuts are tight and the rear wheel is properly secured. (torque: 50Nm) Confirm the front wheel is properly secured by checking that the through axle is torqued to 6 to 8 Nm.
Seat	<ul style="list-style-type: none"> Ensure the seat is securely connected to the eBike and the seat cannot be moved. Confirm the adjustment lever is fully tightened and locked. Verify the seat is properly adjusted to fit your height. Confirm that the seat is securely fastened to the post (torque: 10 Nm).

Handlebar	<ul style="list-style-type: none"> • Confirm the handlebar always aligns with fork when moving in desired direction and both parts turn in unison. • Ensure the steering spring is connected on both ends with no interference from cables. • Secure the front wheel or fork, preventing it from turning. Apply approximately 20 lbs of force to one of the handlebar grips. The handlebar should not rotate independently from the front wheel or fork. • Confirm the stem clamp bolts are tightened to 6 Nm and the stem faceplate bolts are tightened to 6 to 8 Nm.
Chain	<ul style="list-style-type: none"> • Ensure the chain is properly lubricated and runs smoothly. • After using in rough weather conditions such as rain, snow, or other severe weather, verify that chain and links are clean and undamaged. • Confirm the chain tension mechanism is in line with the pedal assembly and derailleur.
Bearings	<ul style="list-style-type: none"> • Verify all bearings are lubricated and run smoothly with no unnatural sounds such as grinding or rattling. • Check the bearings in the headset assembly, pedals and bottom bracket, and the rear wheel.
Crank & Pedals	<ul style="list-style-type: none"> • Confirm pedals are tightly secured to the cranks (torque: 35Nm) and the crank is tightly secured to the bottom bracket spindle (torque: 40Nm). • Verify cranks are parallel to the downtube and not bent.
Frame & Fork	<ul style="list-style-type: none"> • Confirm there is no damage or bending to the front fork and frame and that fork is parallel with the front tire.
Motor Drive Assembly & Throttle	<ul style="list-style-type: none"> • Confirm that none of the spokes securing the hub motor are broken or loose. • Verify that the brake disc is secured to the hub motor and all screws are tight. • Turn on display before ride to confirm all features are working correctly. • Ensure the throttle functions properly.

Battery	<ul style="list-style-type: none"> • Always charge the battery before each use. • Confirm there is no damage to the battery. • Ensure the battery is always securely locked to the frame with the keys removed.
Control Cables	<ul style="list-style-type: none"> • Confirm all cables are routed away from moving parts and allow the headset to rotate freely. • Confirm cables, housings, and electrical connectors are undamaged and free of debris and liquids. • Verify the headlight, taillight, and brake light are connected and functioning properly.
Accessories	<ul style="list-style-type: none"> • Ensure that any loads or accessories do not interfere with moving parts. • Tighten and secure all accessories and accessory components. • Ensure rider is wearing a helmet and the helmet is not damaged.
Reflectors	<ul style="list-style-type: none"> • Verify reflectors are adjusted and outward facing before all rides. • Ensure that loads or accessories do not interfere with reflectors.

Maintenance

Always have a certified and reputable bike mechanic complete a tune-up on your eBike after your first 50-100mi. Regular tune-ups and inspections are critical to ensuring your bike stays in safe condition.

For more information on recommended maintenance intervals please visit:



- After a crash or an incident, do not ride your eBike until you have a certified and reputable bike mechanic inspect the eBike to ensure proper function of the eBike and all its components.
- Any changes to the Flyer™ eBike that are not specifically approved by Radio Flyer Inc. could cause unsafe riding conditions and may void your warranty.

Cleaning

Do not spray with water or use a pressure washer to clean your bike. Do not immerse this product in water or liquid. Liquid or water can cause damage to the electrical system of the eBike.

- To clean, turn off your eBike and remove the battery.
- Wipe clean with a damp cloth. If needed, use a mild soap, like dish detergent.
- To prevent electric shock, do not immerse the charger or battery in water when cleaning. To clean, remove the charger/battery plug from the outlet and wipe with a dry cloth.

Moving & Storage

- Always remove the battery from the eBike before transporting the bicycle on a vehicle bike rack.
- It is recommended to park the eBike indoors.
- Store the battery in a dry location.
- If the eBike will not be used for an extended period, do not store the battery installed in the eBike.
- To maintain battery life, you must charge every 6 months.
- When not using the battery for an extended period, charge the battery to at least 75%
- Do not store the battery in locations where the temperature is below 14°F (-10°C) or above 104°F (40°C)

eBike Battery Recycling

Radio Flyer is a proud member of the first industrywide eBike battery recycling program, administered by Call2Recycle, the largest, most reliable battery recycling program in the U.S., and endorsed by PeopleForBikes, a national bicycling advocacy organization and the bicycle industry's trade association. Radio Flyer has united with more than 40 bike industry leaders to voluntarily support this first of its kind, nationwide initiative to ensure batteries are safely and responsibly managed at their end-of-life. For more information visit www.call2recycle.org/e-bikes.

When your eBike battery reaches its end of life return it to the store for responsible recycling. Scan the QR code below to find an eBike battery recycling location near you.



**e-bike
battery recycling**

powered by Call2Recycle | endorsed by PeopleForBikes



Troubleshooting

Issue	Possible Reason	Corrective Action
The eBike does not work or appear to turn on	The battery has been fully drained	Recharge the battery using the manufacturer provided charger
	The battery is not fully seated or installed into its dock	Remove the battery from the eBike; reinsert the battery and fully seat it into the battery's dock to ensure a connection
	There is a connection issue	Check the connections and wires that are visible on the eBike, repair or clean and connections in a poor state
	The brakes are depressed, not allowing the motor to activate	The brake levers contain a small switch that automatically stops the motor if depressed; for the motor to engage, make sure that the brakes are in the fully open or released position
The eBike feels slow to accelerate and will not reach top speed	The battery is not fully charged and cannot provide full power	Recharge the battery; note that speed and acceleration will worsen when the battery is nearly depleted
	The brakes are applied and slowing down the eBike	Check to see if the brakes are rubbing when riding, adjust the brakes to allow for easier wheel movement
	The eBike is fully loaded or overloaded	Reduce the load to go faster; note that the weight loaded on the eBike will impact the acceleration and top speed of the eBike
The eBike's range is reduced	The battery is not fully charged and cannot provide full power	Recharge the battery between uses and ensure that the battery is fully charged before riding; note that range is directly related to the battery's charge level
	The brakes are applied and slowing down the eBike	Check to see if the brakes are rubbing when riding, adjust the brakes to allow for easier wheel movement
	The eBike is fully loaded or overloaded	Reduce the load to go further; note that the weight loaded on the eBike will impact the range
	The terrain is very rough or hilly	Rough surfaces and inclines make the eBike work harder, riding in these conditions will reduce the range

The battery does not charge	The charger is not fully connected to the battery charge port well	Disconnect the charger from the charger port; reconnect and fully insert into the charger port
	The outlet used does not have power	Charge the battery at a different power socket
The eBike is making an odd noise when moving	The brakes are rubbing	Adjust the brakes to allow for easier wheel movement
	A cable is loose and hitting something	Look to see if any wires are rubbing against moving parts, move or restrain them with zip ties if needed
	The motor or wheel is damaged	Inspect the motor and wheel for damages, replace if needed
	The derailleur is misaligned	It may be necessary to index the derailleur

Error code troubleshooting

Your eBike can detect some functional errors and display a numerical code related to the issue. If your display shows any of the following error code numbers, please try the related corrective action. If the error code remains, please see the troubleshooting information at flyer.radioflyer.com or contact the Radio Flyer Customer Service Team.

Error Code	Possible Reason	Corrective Action
10	Battery Over Voltage - Reporting a higher voltage than expected	Turn the eBike off, remove the battery from frame and wait 1 minute. Reinstall the battery and turn the eBike back on.
11	Low Battery Voltage - the eBike's battery is undercharged and cannot power the motor.	Charge the battery using the manufacturer provided charger.
12	Motor Stall Protection - Potential obstruction is preventing the rear wheel from rotating	Turn the eBike off, remove the obstruction, restart the eBike.
13	Controller Over-Temperature Protection	Turn off the eBike and allow to cool for 15 minutes before restarting.

Error Code	Possible Reason	Corrective Action
14	Controller Communication Error	Turn off the eBike and wait 1 minute. Turn on the eBike.
16	Controller Communication Error	Turn off the eBike and wait 1 minute. Turn on the eBike.
17	Throttle Actuation Error - The throttle is reporting a higher value than expected	Confirm the throttle is not actuated when powering on the bike. If the issue persists, unplug the throttle cable and inspect it. Then, plug the connection back in and restart the eBike.
18	Torque Sensor Communication Error	Unplug the torque sensor cable, inspect it for any debris, moisture, or damage. If it looks okay, plug the connection back in and restart the eBike.
19	Speed Sensor Communication Error	Find the wire that runs from the motor to the eBike frame, inspect it for any damage. Unplug the motor cable, inspect it for any debris, moisture, or damage. If it looks okay, plug the connection back in and restart the eBike.
21	Over Current Protection- The current draw has exceeded the allowable range. A high payload, severe incline, or rough terrain may cause this error.	Turn the eBike off, remove the battery from frame and wait 1 minute. Reinstall the battery and turn the eBike back on.
22	Throttle Communication Error	Unplug the throttle cable, inspect it for any debris, moisture, or damage. If it looks okay, plug the connection back in and restart the eBike.
24	Motor Communication Error - the motor in the rear wheel is not correctly communicating with the controller.	Find the wire that runs from the motor to the eBike frame, inspect it for any damages. Unplug the motor cable, inspect it for any debris, moisture, or damage. If it looks okay, plug the connection back in and restart the eBike.

Error Code	Possible Reason	Corrective Action
25	Brake Communication Error - the eBike's brake levers are not correctly communicating with the controller.	Confirm the throttle is not actuated when powering on the bike. If the issue persists, unplug both brake connectors, inspect them for any debris, moisture, or damage. If the connectors look good, plug a single brake connection back in. Turn on the eBike and check if the error code appears. If the error code does not appear, plug in the second brake connection to check if it is causing the error.
27	Motor Over-Temperature Protection	Reduce pedal-assist level or throttle usage to prevent motor overheating.
30	Controller Communication Error	Turn off the eBike. Unplug the PCM connectors, inspect for any debris, moisture, or damage. If the connectors look good, plug them back in and restart the eBike.
31	Battery Communication Error	Turn the eBike off, remove the battery from frame and wait 1 minute. Reinstall the battery and turn the eBike back on.
40	Battery Over-Temperature Warning	Reduce pedal-assist level or throttle usage to prevent battery overheating.

Common Battery Errors	Possible Reason
4 LEDs on Battery Double-Blink: Low Voltage Protection	The battery needs to be charged. Charge the battery using the manufacturer provided charger.
3 LEDs on the Battery Triple-Blink: Over-Temperature Protection	Remove the battery from the bike and allow it to cool for 15 minutes before restarting the eBike

Warranty

LIMITED WARRANTY FOR E-BIKES: FLYER™ VIA

What is covered?

Radio Flyer Inc. warrants that its Flyer™ e-Bike will be free from defects in material and workmanship occurring under normal use for a period limited to one (1) year from the date of the original purchase. The warranty is expressly limited to the replacement of a defective lithium ion battery (the “Battery”), frame, forks, stem, handlebar, headset, seat post, saddle, brakes, lights, bottom bracket, crank set, pedals, rims, wheel hub, freewheel, cassette, derailleur, shifter, motor, throttle, controller, wiring harness, LCD display, kickstand, reflectors and hardware (each a “Covered Component”).

EXCLUSIONS

Who is covered?

This warranty only covers the original purchaser of the product, purchased exclusively on flyer.radioflyer.com. The warranty cannot be transferred to any other person. The product must have been assembled and maintained per the product instructions.

What is not covered?

This warranty does not cover:

Non-Flyer™ products (including MP3 players); misuse, lack of care, mishandling, accident, abuse or other abnormal use; or use of the product other than for its intended purpose; damage caused by improper or unauthorized repair or maintenance; products that have been modified or altered; cosmetic issues such as fading or scratches from normal wear, or any other cause not arising from defects in material and workmanship, including normal wear and tear of any Covered Component Consumables or normal wear and tear parts (including without limitation tires, tubes, brake pads, cables and housing, grips, chain and spokes).

Any damage or defects to Covered Components resulting from failure to follow instructions in the e-Bike owner's manual, acts of God, accident, misuse, neglect, abuse, commercial use, alterations, modification, improper assembly, installation of parts or accessories not originally intended or compatible with the e-Bike as sold, operator error, water damage, extreme riding, stunt riding, or improper follow-up maintenance.

For the avoidance of doubt, Radio Flyer Inc. will not be liable and/or responsible for any damage, failure or loss caused by any unauthorized service or use of unauthorized parts.

The Battery is not warranted from damage resulting from power surges, use of an improper charger, improper maintenance or other such misuse, normal wear or water damage.

How do I make a warranty claim?

RADIO FLYER INC. WILL NOT REPLACE ANY COVERED COMPONENT UNDER THIS LIMITED WARRANTY WITHOUT FIRST SEEING PHOTOS OR VIDEO OF THE DAMAGED COVERED COMPONENT.

To exercise your right to receive a replacement for a Covered Component under this Limited Warranty, you must:

Contact the Customer Service team by email at customerservice@radioflyer.com or by phone at 1-800-621-7613. Customer Service will work with you to diagnose the issue and identify solutions.

If the Customer Service team determines that a Covered Component must be replaced, they will provide you with a set of instructions for returning the defective Covered Component and receiving the replacement.

After you receive the replacement Covered Component, the Customer Service team will also assist in determining how to replace or install the new Covered Component into your e-Bike.

Replacement Covered Components under this Limited Warranty shall only be shipped to the address of the original purchaser.

SHIPPING DAMAGE

Shipping damage claims are very time sensitive and it is the purchaser's responsibility to immediately inspect the e-Bike for damage upon receipt. Radio Flyer Inc. will replace a Covered Component that is damaged during shipment if you:

Notify Radio Flyer Inc. of a Covered Component damaged in the shipping process within thirty (30) days of your receipt of the e-Bike; Provide Radio Flyer Inc. with a dated picture of the damaged Covered Component; and Return all original packaging and paperwork included with the e-Bike

Radio Flyer Inc. will not be held responsible for stolen packages and the purchaser is solely responsible for ensuring the package is safely collected at delivery. To more closely control, manage and monitor your delivery, we encourage you to sign up for a free UPS My Choice account. You can learn more about this UPS service and sign up [here](#).

SOLE AND EXCLUSIVE REMEDY

Your sole and exclusive remedy for breach of this limited warranty, and Radio Flyer Inc.'s sole and exclusive liability, is to either repair or replace the defective product. Repaired or replaced products will be warranted to the end of the warranty period of the original product. They do not extend the original warranty period.

DISCLAIMERS

This Limited Warranty is the only express warranty made to you and is provided in lieu of any other express warranties or similar obligations (if any) created by any advertising, documentation, packaging, or other communications.

EXCEPT FOR THE LIMITED WARRANTY AND TO THE MAXIMUM EXTENT PERMITTED BY APPLICABLE LAW, RADIO FLYER INC. HEREBY DISCLAIMS ALL OTHER WARRANTIES AND CONDITIONS, WHETHER EXPRESS, IMPLIED OR STATUTORY, INCLUDING, BUT NOT LIMITED TO, THE IMPLIED WARRANTY OF MERCHANTABILITY OR OF FITNESS FOR A PARTICULAR PURPOSE.

IN NO EVENT SHALL RADIO FLYER INC. OR ITS SUPPLIERS BE LIABLE TO YOU OR ANY THIRD PARTY FOR ANY INDIRECT, INCIDENTAL, CONSEQUENTIAL, SPECIAL OR EXEMPLARY DAMAGES ARISING OUT OF THE USE OF THE PRODUCT, INCLUDING, WITHOUT LIMITATION, PROPERTY DAMAGE, LOSS OF VALUE OF THE PRODUCT OR LOSS OF USE OF THE PRODUCT, EVEN IF RADIO FLYER INC. HAS BEEN ADVISED OF THE POSSIBILITY OF SUCH DAMAGES.

Some states do not allow the limitation of implied warranties or the exclusion of consequential or incidental damages, therefore the above limitation of implied warranties or the exclusion of consequential or incidental damages may not apply to you. This warranty gives you specific legal rights and you may also have other rights which may vary from state to state.

Federal Communications Commission (FCC) Compliance Statement for USA

This device complies with part 15 of the FCC rules. Operation is subject to the following two conditions: (1) This device may not cause harmful interference, and (2) this device must accept any interference received, including interference that may cause undesired operation.

Note: This equipment has been tested and found to comply with the limits for a Class B digital device, pursuant to part 15 of the FCC Rules. These limits are designed to provide reasonable protection against harmful interference in a residential installation. This equipment generates, uses, and can radiate radio frequency energy; if not installed and used in accordance with the instructions, it may cause harmful interference to radio communications. There is no guarantee that interference will not occur in a particular installation. If this equipment does cause harmful interference to radio or television reception, which can be determined by powering the equipment off and on, the user is encouraged to try to correct the interference by using any of the following measures:

- Reorienting or relocating the receiving antenna.
- Increasing the separation between the equipment and receiver.
- Connecting the equipment into an outlet on a circuit different from that to which the receiver is connected. Consult the dealer or an experienced radio/TV technician for help.

This equipment complies with FCC radiation exposure limits set forth for an uncontrolled environment.

Caution: Changes or modifications not expressly approved by the party responsible for compliance could void the user's authority to operate the equipment.